



**KARER**

**TECHNICAL  
BROCHURE**

## **UL 3**

**3 M<sup>3</sup> BUCKET VOLUME, 7 TONS TRAMMING CAPACITY**

**UNDERGROUND LOADER WITH HIGH PAYLOAD CAPACITY AND ADVANCED CONTROL SYSTEM**



*KARER UL 3 is a loader designed for narrow lanes with a payload of 7 tons.*

*The Stage V (Euro 5) model meets stringent emission requirements with a VOLVO engine. Its fast and easy loading features offer its users the highest possible efficiency.*

*The optimized working mechanism can provide excellent shoveling force to meet the needs of fast shoveling and large ore processing; the powerful hydraulic system can lift the boom and tip the bucket at the same time, making shoveling more efficient.*

*The independent enclosed cab equipped with air-conditioning system improves the safety and comfort of the operator; it is equipped with Intelligent Control System and a 7- inch color display to display the machine's status information and fault alarm information.*

*You have peace of mind with the high-efficiency, low-fuel consumption, easy-to-access spare parts Volvo (Sweden) brand engine.*

*It improves the working environment in terms of noise and emissions thanks to its silencer, DOC + DPF + SCR + ASC and Stage V (Euro 5) Volvo brand engine.*

CAPACITIES	
Standard Bucket Volume	3 m <sup>3</sup>
Tramming	7.000 kg
Max Breakout Force, Lift	115.000 N
Max Breakout Force, Tilt	167.000 N
Oscillation Angle	8°

DIMENSIONS	
Length*Width*Height	920*235*226cm
Min. Ground Clearance	28 cm
Max Lift Height	493 cm
Max Unloading Height	179 cm

MOVEMENT TIMES	
Raising	6.7 second
Lowering	3.3 second
Dumping	0.9 second

SPEEDS	
Speed (1st Gear)	4.4 km/h
Speed (2nd Gear)	8.5 km/h
Speed (3rd Gear)	16.5 km/h
Speed (4th Gear)	23.2 km/h

WEIGHTS	
Operating Weight	19,200 kg
Loaded Weight	26,200 kg
Front Axle (Unloaded)	9,400 kg
Rear Axle (Unloaded)	9,800 kg
Front Axle (Loaded)	20,700 kg
Rear Axle (Loaded)	5,500 kg
*Machine weight depends on options selected	

TRANSMISSION	
Torque Converter	
Brand	DANA
Model	C273
Gearbox	
Brand	DANA
Model	T14
Features	Electronic shift Gear shifting operation and steering with integrated control Four gears forward and reverse

AXLES	
Brand	Kessler (Germany)
Front Axle	Model: D91 SAHR Standard
Rear Axle	Model: D91 SAHR No-Spin

BRAKES	
Service brake, spring-hydraulic release (SAHR), fully enclosed, multiple wet discs at each wheel end	
Parking brake, spring-hydraulic release (SAHR), fully enclosed, multiple wet discs at each wheel end	
Emergency brake, spring-hydraulic release (SAHR), fully enclosed, multiple wet discs at each wheel end	
Manual emergency brake release pump is standard. In case of engine stoppage, loader can be easily withdrawn from underground	



ENGINE	
Model	VOLVO TAD 582 VE
Power	160kW@2300rpm
Max. Torque	925 Nm@1380rpm
Cylinder	In Line 6
Electric	24 V
Control System	Electronic fuel injection system
Fuel System	Integrated hand oil pump, remote fuel filter
Cooling System	Water-cooled engine Direct drive fan
Starter	5.5 kW motor
Emission	Stage V (Euro 5)
Air Intake	Low turbocharger Dry air filtration Prefiltration Two-stage filtration
Exhaust System	DOC + DPF + SCR + ASC

TANK CAPACITIES	
Fuel Tank	200 liters
Hydraulic Oil Tank	320 liters

ELECTRIC	
Battery	2 * 12V, 100 Ah
Starter	5.5 kW / 24 V
Dynamo	24 V, 110 A
Horn/Back-up siren is standard	
Flashing warning lights are standard	
Control System	Programmable
	Built-in diagnostic system
	7 " color display
Driving Lights	
Front (Upper of Arm)	3 pcs LED
Rear View	2 pcs LED
Canopy (inside)	3 pcs LED



CANOPY	
ROPS certified according to ISO 3471	
FOPS certified according to ISO 3449	
Air conditioner	
Sound-absorbing and flame-retardant interior materials	
Air conditioner and canopy are installed independently	
Emergency exit	
Laminated glass windows	
Washable canopy floor to reduce dust	
Adjustable operating handle and armrest	
Three-point entry system for the cab	
Main circuit breaker release button	
Seating area with very good two-way visibility and comfortable use during operation	

DASHBOARD	
The color display 7" screen can flexibly switch between various interfaces and adjust brightness, time, download/upload programs and other operations	
Display screen can display vehicle parameters and various alarm information, allowing the operator to understand the real-time status of the loader and operate the loader more efficiently and safely	
Intelligent control system	
Warning and alarm systems have sound and light prompt	
Dashboard is 7" color display	
Dashboard has fully functional rocker switch button control	

SEAT	
The driver's seat is an adjustable spring-shock-absorbing seat with a three-point safety belt	
The seat can be adjusted up and down, front and back	
The seat is equipped with a padded arm rest and an adjustable joystick that can be installed on the canopy door or the right wall of the canopy	
Spring shock absorber	
Height adjustable	
Adjustable according to operator weight	
Adjustable arm rests	
Adjustable back support	

WHEELS	
Tire Dimensions	17.5-R25 L-5S

FRAME (CHASSIS)	
High-strength, heavy impact and load resistant steel structure with optimized material thickness	
The heavy-duty design of the rear frame can better stabilize the equipment when lifting and shoveling ore.	
Bucket made of high-strength, wear-resistant steel	
Adopt high-strength alloy steel plate, optimize material thickness, improve overall transportation capacity, and prolong the structure life	

The working mechanism boom adopts a box-type structure, which provides strong resistance to impact loads and is optimized to reduce stress and extend the service life  
 Work organization is reverse six-bar

### HYDRAULICS

When machine is shutdown, axles brakes  
 Working efficiency is increased with 2 radiators, namely hydraulic oil radiator and transmission oil radiator  
 Trouble-free performance with 320 liters hydraulic oil tank  
 Hydraulic pilot control  
 Lifting cylinder is 2 pcs  
 Tipping cylinder is 1 pc  
 Working main valve is middle open center  
 Working pump is gear type metering pump

### STEERING

Fully hydraulic central articulated steering  
 Hydraulic joystick is used for steering  
 Hydraulic pilot control  
 Steering main valve is middle open center  
 Steering hydraulic cylinder is 2 pcs  
 Steering pump is gear type metering pump

### WORKING ENVIRONMENT CONDITIONS

Temp.	-15°C ~ +45°C
Altitude	When working at -1,500 meters to +2,500 meters, there is no power loss at an ambient temperature of 25°C

### STANDARD FEATURES

Portable fire extinguisher  
 Heat source isolation protection cover  
 Exhaust pipe insulation cotton protection  
 Turbocharger guard  
 Main power switch can be locked  
 Emergency stop button  
 Manual pressure release cap for engine water tank  
 Manual pressure relief device for accumulator  
 Front and rear rack locking device  
 Arm locking device

### OPTIONAL ENGINE

Model	VOLVO TAD850 VE
Power	160kW@2200rpm
Max. Torque	1060 Nm@1350rpm
Cylinder	In Line 6
Electric	24 V
Control System	Electronic fuel injection system
Fuel System	Integrated hand oil pump, remote fuel filter
Cooling System	Water-cooled engine Direct drive fan
Starter	5.5 kW motor
Emission	Euro 3
Air Intake	Low turbocharger Dry air filtration Prefiltration Two-stage filtration
Exhaust System	Catalytic Purifier + Silencer



### OPTIONS

Remote control system  
 Engine fire extinguishing system  
 Manual centralized lubrication system  
 Automatic centralized lubrication system  
 Automatic dry powder fire extinguishing  
 Manual dry powder fire extinguishing  
 Electric emergency brake release pump  
 Line-of-sight remote control system  
 G.E.T. (ground engaging tools)  
 Driving recorder  
 Customize other bucket capacity  
 Automatic shift series  
 Anti-collision system  
 Production management system



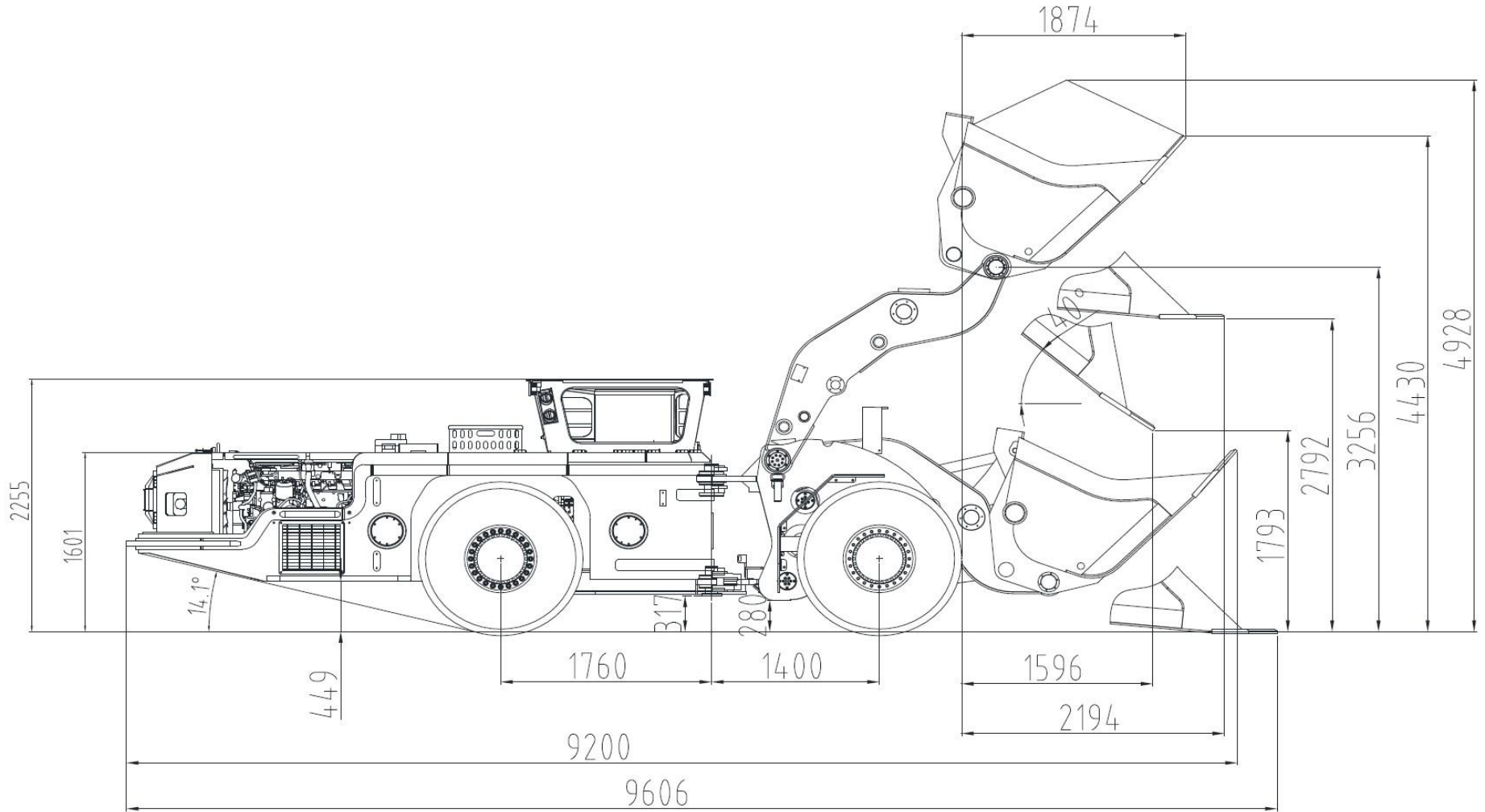

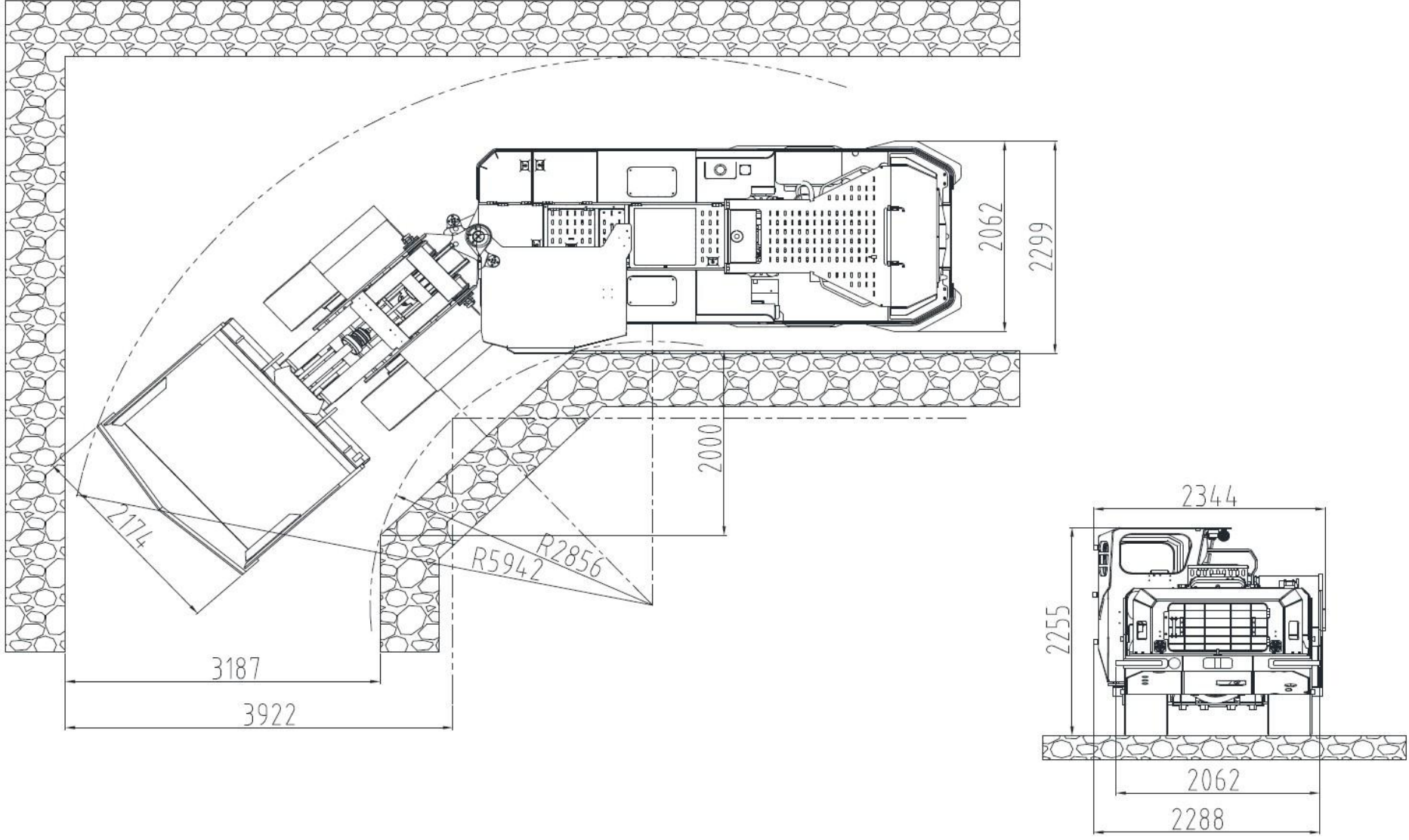



KARER KARADAVUT ERDEM MAKİNA ENERJİ SANAYİ VE TİCARET LİMİTED ŞİRKETİ

+90 553 531 77 50 satis@karer.tr

Ostim OSB Mh. 1235. Cd. No:81 Yenimahalle / ANKARA

www.karer.tr