

Axial piston variable double pump A20VO, A20VNO, A20VLO series 10

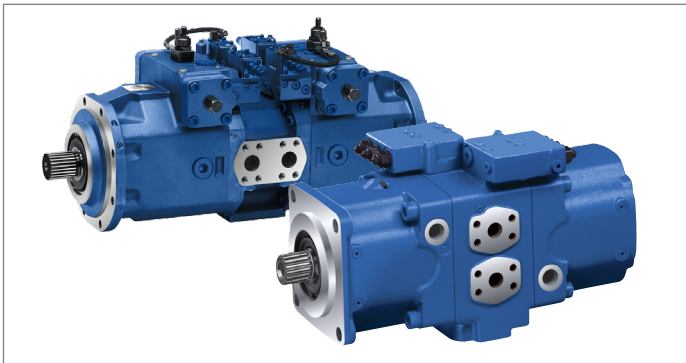

- ▶ Compact back-to-back pump for machines with multi-circuit system
- ▶ Sizes 60 and 72:
Nominal pressure 250 bar, maximum pressure 315 bar
- ▶ Size 85:
Nominal pressure 210 bar, maximum pressure 250 bar
- ▶ Sizes 95 to 520:
Nominal pressure 350 bar, maximum pressure 400 bar
- ▶ Open circuit

Features

- ▶ Variable double pump with two axial piston rotary groups with swashplate design for hydrostatic drives in an open circuit.
- ▶ Flow is proportional to the drive speed and displacement.
- ▶ The flow can be continuously changed with closed loop control.
- ▶ For use in mobile and industrial application areas.
- ▶ The pump consists of proven components of the variable displacement

Pumps	Data sheet
A11VO	92500
A10VO/5x	92703
A10VNO	92735
A4VSO	92050

- ▶ An extensive range of control devices is available in the respective data sheets for different control and regulating functions.
- ▶ Pump operation can be self-priming, with a priming reservoir, or with a charge pump (NG 190 and 260).
- ▶ Power setting is possible from the outside, even while the machine is running (only with power controller).
- ▶ The through drive is suitable for mounting gear pumps and axial piston pumps.

Contents

Type code	2
Hydraulic fluids	4
Filtration of the hydraulic fluid	5
Working pressure range size 60 to 520	6
Technical data – For additional technical data see data sheets 92703, 92735, 92500 and 92050	10
Examples of control devices	12
Dimensions of nominal size 60 to 520 without control device	14
Through drive dimensions, size 60 to 520	24
Overview of mounting options	30
Combination pumps A20V(N)O + A10VO	30
Installation instructions	31
Below-reservoir installation (standard)	32
Project planning notes	37
Safety instructions	38
Related documentation	39

Type code

01	02	03	04	05	06	07	08	09	10	11	12
A20V		O			/	10	-				

Axial piston unit

01	Swashplate design, variable (back to back version)											A20V
----	--	--	--	--	--	--	--	--	--	--	--	-------------

Additional function

		60	72	85	95	190	260	520	
02	Without charge pump for standard pressure area (without code)	●	●	-	●	-	-	●	
	Without charge pump for low pressure area	-	-	●	-	-	-	-	N
	With charge pump	-	-	-	-	●	●	-	L

Operating mode

03	Double pump, open circuit	●	●	●	●	●	●	●	O
----	---------------------------	---	---	---	---	---	---	---	----------

Size (NG)

04	Geometric displacement per rotary group, see "Technical data" on page 10 supplementary data sheets	60	72	85	95	190	260	520	
----	--	-----------	-----------	-----------	-----------	------------	------------	------------	--

Control device

		60	72	85	95	190	260	520		
05	Control for sizes 60, 72 and 85	92703 and 92735	●	●	●	-	-	-	-	DRG
			●	●	●	-	-	-	-	DFR
	Controls for size 95, 190, 260	-	-	-	●	●	●	-		
05	Controls for size 520	92050, 92064	-	-	-	-	-	-	●	LR3N
			-	-	-	-	-	-	●	LR2DN
			-	-	-	-	-	-	●	LR3DN
			-	-	-	-	-	-	●	LR3GN
			-	-	-	-	-	-	●	LR2NT
	92076	-	-	-	-	-	-	○	HS5	

Series

06	Series 1, index 0	●	●	●	●	●	●	●	10
----	-------------------	---	---	---	---	---	---	---	-----------

Directions of rotation

		60	72	85	95	190	260	520	
07	Viewed on drive shaft	●	●	●	●	●	●	●	R
		●	●	●	●	●	●	●	L

Sealing material

		60	72	85	95	190	260	520	
08	NBR (nitrile rubber), shaft seal ring FKM (fluorocarbon rubber)	-	-	-	●	●	●	-	N
	FKM (fluorocarbon rubber)	●	●	●	●	●	●	●	V

Drive shaft

		60	72	85	95	190	260	520	
09	Splined shaft DIN 5480	-	-	-	●	●	●	●	Z
	Splined shaft ISO 3019-1	●	●	●	-	-	-	-	S
	Splined shaft ANSI B92.1a	-	-	-	●	-	-	-	
		-	-	-	-	●	●	-	T

Mounting flange

		60	72	85	95	190	260	520	
10	ISO 3019-1	●	●	●	●	●	●	-	D
	Based on SAE J617 (SAE 3)	-	-	-	●	●	-	-	G
	Based on ISO 3019-2	-	-	-	-	-	-	●	H

● = Available ○ = On request - = Not available

01	02	03	04	05	06	07	08	09	10	11	12
A20V		O			/	10	-				

Working port

		60	72	85	95	190	260	520	
11	SAE flanges, two port B and one port S laterally opposite, metric fastening thread	●	●	●	●	●	●	-	24
	SAE flanges, two port B laterally opposite and one port S offset 90°, metric fastening thread	-	-	-	-	-	-	●	26

Through drive

12	Flange ISO 3019-1 (SAE)		Hub for splined shaft ¹⁾									
	Diameter	Mounting	Diameter		60	72	85	95	190	260	520	
	Without through drive				-	-	-	●	●	●	-	N00
	Ready for through drive, without hub, without intermediate flange, plugged with pressure-resistant cover				-	-	-	-	-	-	●	K99
	82-2 (A)	5/8 in	9T 16/32DP	●	●	●	●	●	●	●	-	K01
		3/4 in	11T 16/32DP	●	●	●	-	-	-	-	-	-
	101-2 (B)	7/8 in	13T 16/32DP	-	-	-	●	●	●	●	-	K02
		1 in	15T 16/32DP	-	-	-	●	●	●	●	-	K04
		7/8 in	13T 16/32DP	●	●	●	-	-	-	-	-	-
	127-2 (C)	1 1/4 in	14T 12/24DP	-	-	-	●	●	●	●	●	K07

● = Available ○ = On request - = Not available

Notice

- ▶ Note the project planning notes on page 37.
- ▶ In addition to the type code, please specify the relevant technical data when placing your order.

¹⁾ In accordance with ANSI B92.1a

Hydraulic fluids

The variable pump A20VO, A20VNO, A20VLO is designed for operation with HLP mineral oil according to DIN 51524. Application instructions and requirements for hydraulic fluid selection, behavior during operation as well as disposal and environmental protection should be taken from the following data sheets before the start of project planning:

- ▶ 92703 (size 60, 72):
Axial piston variable pump A10VO series 52/53
- ▶ 92735 (size 85):
Axial piston variable pump A10VNO series 53
- ▶ 92500 (size 95, 190, 260):
Axial piston variable pump A11V(L)O series 1x
- ▶ 92050 (size 520)
Axial piston variable pump A4VSO series 30

Selection of hydraulic fluid

Bosch Rexroth evaluates hydraulic fluids on the basis of the Fluid Rating according to the technical data sheet 90235.

Hydraulic fluids with positive evaluation in the Fluid Rating are listed in the following data sheet:

- ▶ 90245: Bosch Rexroth Fluid Rating List for Rexroth hydraulic components (pumps and motors)

Selection of hydraulic fluid shall make sure that the operating viscosity in the operating temperature range is within the optimum range (v_{opt} ; see selection diagram).

Viscosity and temperature of hydraulic fluids

	Viscosity	Shaft seal	Temperature ²⁾	Comment
Cold start	$v_{max} \leq 1600 \text{ mm}^2/\text{s}$	NBR ³⁾	$\vartheta_{St} \geq -40 \text{ }^\circ\text{C}$	$t \leq 3 \text{ min}$, without load ($p \leq 50 \text{ bar}$), $n \leq 1000 \text{ rpm}$ Permissible temperature difference between axial piston unit and hydraulic fluid in the system maximum 25 K
		FKM	$\vartheta_{St} \geq -25 \text{ }^\circ\text{C}$	
Warm-up phase	$v = 1600 \dots 400 \text{ mm}^2/\text{s}$			$t \leq 15 \text{ min}$, $p \leq 0.7 \times p_{nom}$ and $n \leq 0.5 \times n_{nom}$
Permissible operating range	$v = 400 \dots 10 \text{ mm}^2/\text{s}^{1)}$	NBR ³⁾	$\vartheta_{St} \leq +85 \text{ }^\circ\text{C}$	measured at port T or L_x
		FKM	$\vartheta_{St} \leq +110 \text{ }^\circ\text{C}$	
	$v_{opt} = 36 \dots 16 \text{ mm}^2/\text{s}$			optimal operating viscosity and efficiency range
Short-term operation	$v_{min} = 10 \dots 7 \text{ mm}^2/\text{s}$	NBR ³⁾	$\vartheta_{St} \leq +85 \text{ }^\circ\text{C}$	$t \leq 3 \text{ min}$, $p \leq 0.3 \times p_{nom}$, measured at port T or L_x
		FKM	$\vartheta_{St} \leq +110 \text{ }^\circ\text{C}$	

▼ Selection diagram

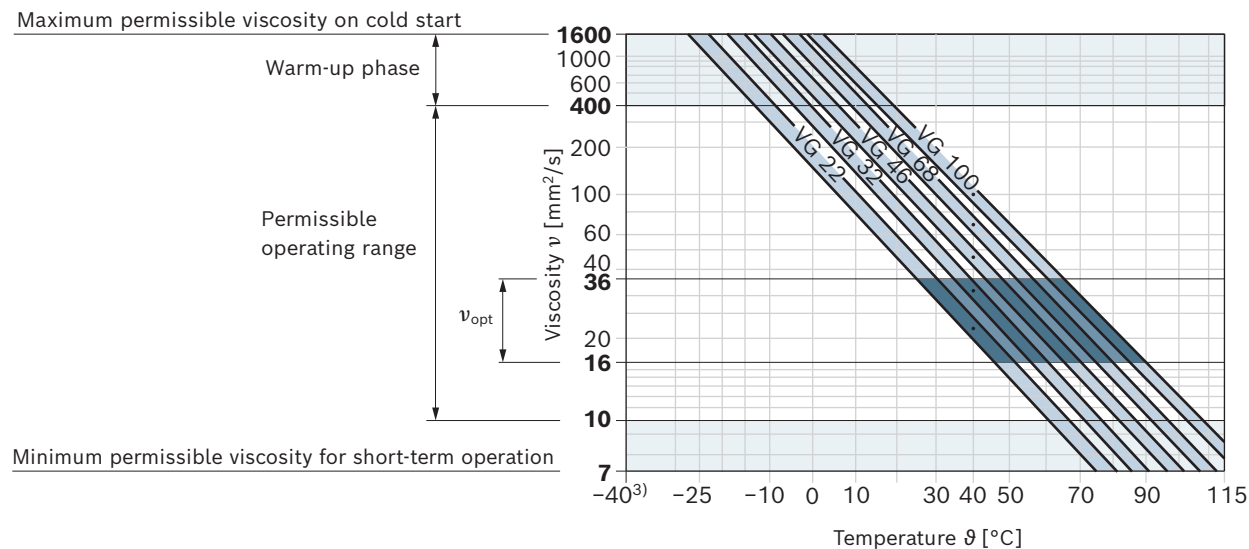

1) This corresponds, e.g. on the VG 46, to a temperature range of +4 °C to +85 °C (see selection diagram)

2) If the temperature at extreme operating parameters cannot be adhered to, please contact us.

3) Special version, please contact us

Filtration of the hydraulic fluid

Finer filtration improves the cleanliness level of the hydraulic fluid, which increases the service life of the axial piston unit.

A cleanliness level of at least 20/18/15 is to be maintained according to ISO 4406

At a hydraulic fluid viscosity of less than 10 mm²/s (e.g. due to high temperatures during short-term operation) at the drain port, a cleanliness level of at least 19/17/14 under ISO 4406 is required.

Examples of temperatures of hydraulic fluids at a viscosity of 10 mm²/s:

- ▶ 73 °C at HLP 32
- ▶ 85 °C at HLP 46

Notice

- ▶ Refer to data sheets 92050 (NG 520) and 92500 (NG95, 190, and 260) for housing flushing, bearing flushing, leakage pressures, and charge pump information.

Working pressure range size 60, 72

Pressure at working port B		Definition
Nominal pressure p_{nom}	250 bar	The nominal pressure corresponds to the maximum design pressure.
Maximum pressure p_{max}	315 bar	The maximum pressure corresponds to the maximum working pressure within a single operating period. The sum of single operating periods must not exceed the total operating period.
Single operating period	2.5 ms	
Total operating period	300 h	
Minimum pressure $p_{B absolute}$ (high-pressure side)	10 bar	Minimum pressure on the high-pressure side (B) which is required in order to prevent damage to the axial piston unit.
Rate of pressure change $R_{A max}$	16000 bar/s	Maximum permissible speed of pressure build-up and reduction during a pressure change across the entire pressure range.
Pressure at suction port S (inlet)		
Minimum pressure $p_{S min}$	0.8 bar absolute	Minimum pressure at suction port S (inlet) which is required to prevent damage to the axial piston unit. The minimum pressure depends on the rotational speed and displacement of the axial piston unit (see diagram "Maximum permissible rotational speed" in data sheet 92703)
Maximum pressure $p_{S max}$	5 bar absolute	
Case pressure at port L, L ₁ , L ₂		
Maximum pressure $p_{L max}$	2 bar	Maximum 0.5 bar higher than inlet pressure at port S, but not higher than $p_{L max}$. The case pressure must always exceed the ambient pressure. A case drain line to the reservoir is required.
Pilot pressure port X with external high pressure		
Maximum pressure p_{max}	315 bar	For the design of all control lines pressurized with external high pressure, the values for the rate of pressure change, maximum single operating period and total operating period applicable to port B must not be exceeded.

Notice

- ▶ Working pressure range applies when using hydraulic fluids based on mineral oils. Please contact us for values for other hydraulic fluids.

▼ Rate of pressure change $R_{A max}$

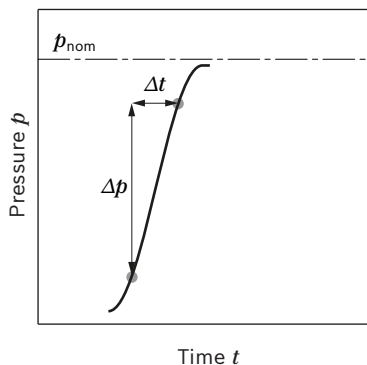

▼ Pressure definition

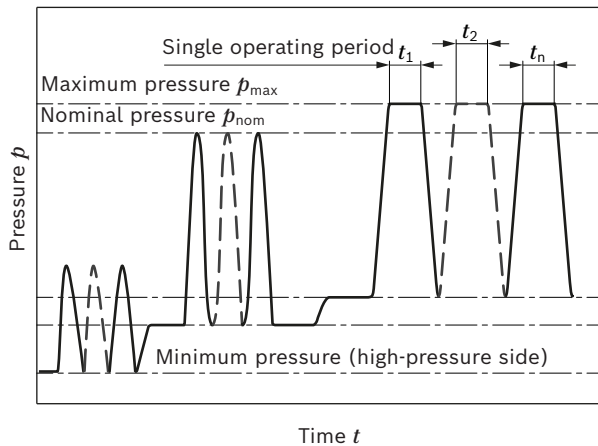

$$\text{Total operating period} = t_1 + t_2 + \dots + t_n$$

Working pressure range size 85

Pressure at working port B		Definition
Nominal pressure p_{nom}	210 bar	The nominal pressure corresponds to the maximum design pressure.
Maximum pressure p_{max}	250 bar	The maximum pressure corresponds to the maximum working pressure within a single operating period. The sum of single operating periods must not exceed the total operating period.
Single operating period	2.5 ms	
Total operating period	300 h	
Minimum pressure $p_{B absolute}$ (high-pressure side)	10 bar	Minimum pressure on the high-pressure side (B) which is required in order to prevent damage to the axial piston unit.
Rate of pressure change $R_{A max}$	16000 bar/s	Maximum permissible speed of pressure build-up and reduction during a pressure change across the entire pressure range.
Pressure at suction port S (inlet)		
Minimum pressure $p_{S min}$	0.8 bar absolute	Minimum pressure at suction port S (inlet) which is required to prevent damage to the axial piston unit. The minimum pressure depends on the rotational speed and displacement of the axial piston unit (see diagram "Maximum permissible rotational speed" in data sheet 92735)
Maximum pressure $p_{S max}$	5 bar absolute	
Case pressure at port L, L ₁ , L ₂		
Maximum pressure $p_{L max}$	2 bar	Maximum 0.5 bar higher than inlet pressure at port S, but not higher than $p_{L max}$. The case pressure must always exceed the ambient pressure. A case drain line to the reservoir is required.
Pilot pressure port X with external high pressure		
Maximum pressure p_{max}	250 bar	For the design of all control lines pressurized with external high pressure, the values for the rate of pressure change, maximum single operating period and total operating period applicable to port B must not be exceeded.

Notice

- ▶ Working pressure range applies when using hydraulic fluids based on mineral oils. Please contact us for values for other hydraulic fluids.

▼ Rate of pressure change $R_{A max}$

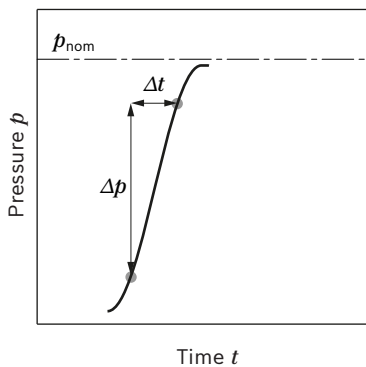

▼ Pressure definition

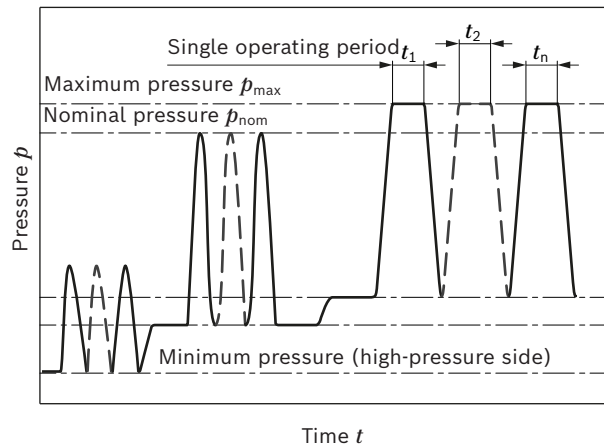

$$\text{Total operating period} = t_1 + t_2 + \dots + t_n$$

Working pressure range sizes 95, 190, and 260

Pressure at working port A		Definition
Nominal pressure p_{nom}	350 bar	The nominal pressure corresponds to the maximum design pressure.
Maximum pressure p_{max}	400 bar	The maximum pressure corresponds to the maximum working pressure within a single operating period. The sum of single operating periods must not exceed the total operating period.
Single operating period	< 1 s	
Total operating period	300 h	
Minimum pressure $p_{A absolute}$ (high-pressure side)	see diagram "Minimum pressure (high-pressure side)"	Minimum pressure on the high-pressure side A required to prevent damage to the axial piston unit
Rate of pressure change $R_{A max}$	16000 bar/s	Maximum permissible pressure build-up and pressure drop rate for a pressure change over the entire pressure range.
Pressure at suction port S (inlet)		
Size 95		
Minimum pressure $p_{S min}$	≥ 0.8 bar absolute	Minimum pressure at suction port S (inlet) which is required to prevent damage to the axial piston unit. The minimum pressure depends on the rotational speed and displacement of the axial piston unit (see diagram "Maximum permissible rotational speed" in data sheet 92500).
Maximum pressure $p_{S max}$	≤ 30 bar absolute ¹⁾	
Sizes 190 and 260		
Minimum pressure $p_{S min}$	≥ 0.6 bar absolute	Minimum pressure at suction port S (inlet) which is required to prevent damage to the axial piston unit.
Maximum pressure $p_{S max}$	≤ 2 bar absolute	
Case pressure at port T ₁ , T ₂		
Maximum case pressure $p_{T max}$	2 bar	Measured at port T₁, T₂ Maximum 1.2 bar higher than inlet pressure at port S , but not higher than $p_{T max}$. A drain line to the reservoir is required.

Minimum pressure (high-pressure side)

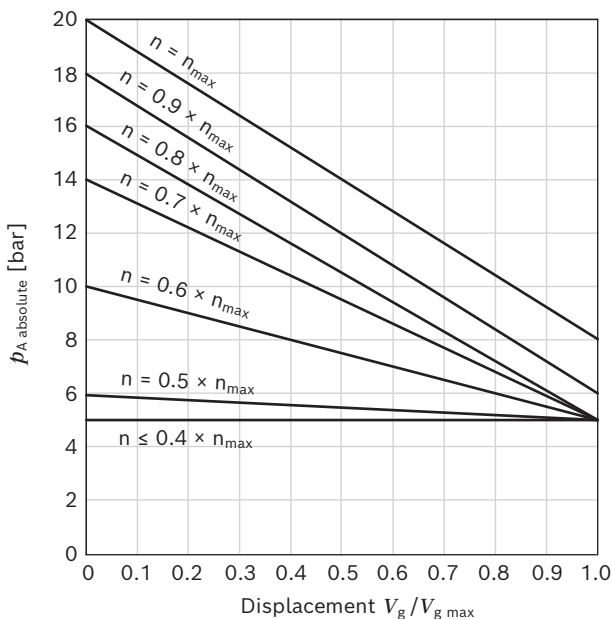

Pressure definition

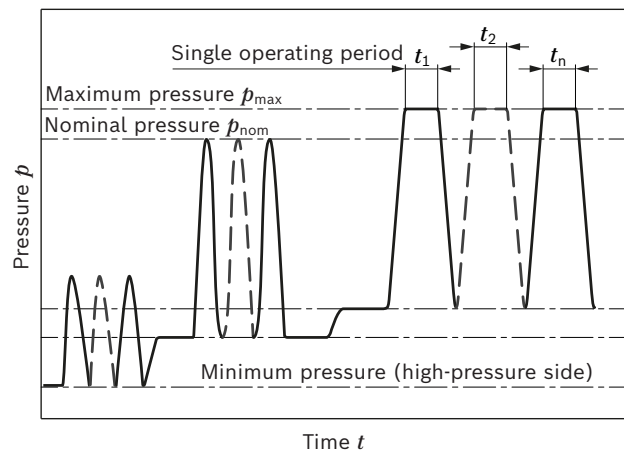

Total operating period = $t_1 + t_2 + \dots + t_n$

Notice

- ▶ Working pressure range applies when using hydraulic fluids based on mineral oils. Please contact us for values for other hydraulic fluids.
- ▶ The case pressure must be greater than the external pressure (ambient pressure) at the shaft seal.

1) > 5 bar, please contact us

Working pressure range size 520

Pressure at working port B		Definition
Nominal pressure p_{nom}	350 bar	The nominal pressure corresponds to the maximum design pressure.
Maximum pressure p_{max}	400 bar	The maximum pressure corresponds to the maximum working pressure within a single operating period. The sum of the single operating periods must not exceed the total operating period (maximum number of cycles: approx. 1 million).
Single operating period	1 s	
Total operating period	300 h	
Minimum pressure $p_{B \text{ absolute}}$ (high-pressure side)	15 bar ¹⁾	Minimum pressure on the high-pressure side (B) which is required in order to prevent damage to the axial piston unit. The minimum pressure depends on the rotational speed and the swivel angle.
Rate of pressure change $R_{A \text{ max}}$	16000 bar/s	Maximum permissible speed of pressure build-up and reduction during a pressure change across the entire pressure range.
Pressure at suction port S (inlet)		
Version without charge pump		Minimum pressure at suction port S (inlet) which is required to prevent damage to the axial piston unit. The minimum pressure depends on the rotational speed and displacement of the axial piston unit (see diagram "Maximum permissible rotational speed").
Minimum pressure $p_{S \text{ min}}$	≥ 0.8 bar absolute	
Maximum pressure $p_{S \text{ max}}$	≤ 30 bar	
Case pressure at port T, K ₁ , K ₂ , R(L)		
Max. static pressure $p_{L \text{ max}}$	4 bar absolute	Maximum 1.2 bar higher than inlet pressure at port S, but not higher than $p_{L \text{ max}}$. See also diagram "Case pressure". A drain line to the reservoir is required.
Pressure peaks $p_{L \text{ peak}}$	6 bar absolute	$t < 0.1$ s

▼ Rate of pressure change $R_{A \text{ max}}$

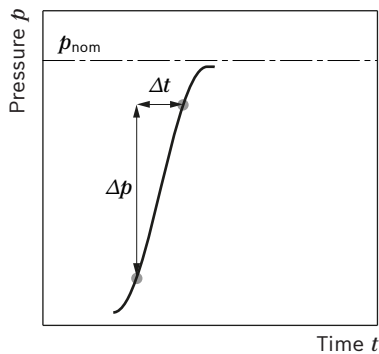

▼ Pressure definition

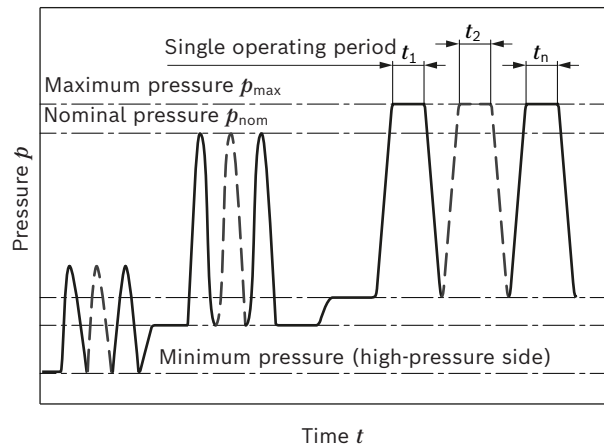

▼ Case pressure NG 520

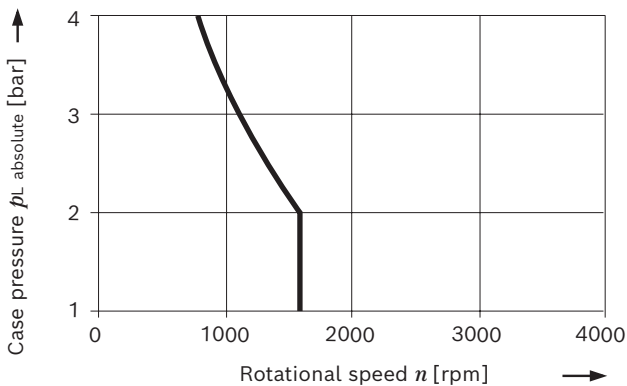

Total operating period = $t_1 + t_2 + \dots + t_n$

Notice

- ▶ Working pressure range applies when using hydraulic fluids based on mineral oils. Please contact us for values for other hydraulic fluids.

1) Lower values on request

Technical data – For additional technical data see data sheets 92703, 92735, 92500 and 92050

Size		NG	60	72	85	95	190	260	520	
Displacement, geometric, per revolution (by rotary group)		$V_{g \max}$	cm ³	60	72	85	93.8	192.7	260	520
		$V_{g \min}$	cm ³	0	0	0	0	0	0	0
Maximum rotational speed ¹⁾	at $V_{g \max}$ ²⁾	n_{nom}	min ⁻¹	2700	2600	2700	2350	2500 ³⁾	2300 ³⁾	1450
	at $V_g \leq V_{g \max}$	n_{max}	min ⁻¹	3140 ⁴⁾	3140 ⁴⁾	–	2780 ⁴⁾	2500	2300	1720 ⁴⁾
Flow	at n_{nom} and $V_{g \max}$	q_v	l/min	2 x 162	2 x 187	2 x 230	2 x 220	2 x 482	2 x 598	2 x 754
Performance at n_{nom} , $V_{g \max}$	and $\Delta p = 210$ bar	P	kW	–	–	160	–	–	–	–
	and $\Delta p = 250$ bar	P	kW	135	154	–	–	–	–	–
	and $\Delta p = 350$ bar	P	kW	–	–	–	257	562	698	880
Torque at $V_{g \max}$	and $\Delta p = 210$ bar ²⁾	M_{max}	Nm	–	–	568	–	–	–	–
	and $\Delta p = 250$ bar ²⁾	M_{max}	Nm	477	572	–	–	–	–	–
	and $\Delta p = 350$ bar ²⁾	M_{max}	Nm	–	–	–	1045	2147	2897	5793
Rotary stiffness of drive shaft	Z	c	kNm/rad	–	–	–	199.6	346.2	686.5	1136
	S	c	kNm/rad	65.5	65.5	65.5	173.7	–	–	–
	T	c	kNm/rad	–	–	–	–	301.9	567.1	–
Moment of inertia		J_{TW}	kgm ²	0.0113	0.0113	0.0113	0.0346	0.1127	0.1773	0.696
Maximum angular acceleration ⁵⁾		α	rad/s ²	3300	3300	2500	13000	6800	4800	2800
Case volume approx.		V	l	1.6	1.6	1.6	4.2	7.6	9.2	28
Weight (without through drive) approx. ⁶⁾		m	kg	44	44	44	107	213	275	640

Determination of the characteristics		
Flow	$q_v = \frac{V_g \times n \times \eta_v}{1000}$	[l/min]
Torque	$M = \frac{V_g \times \Delta p}{20 \times \pi \times \eta_{hm}}$	[Nm]
Power	$P = \frac{2 \pi \times M \times n}{60000} = \frac{q_v \times \Delta p}{600 \times \eta_t}$	[kW]

Notice

- ▶ Theoretical values, without efficiency and tolerances; values rounded
- ▶ Operation above the maximum values or below the minimum values may result in a loss of function, a reduced service life or in the destruction of the axial piston unit. Bosch Rexroth recommends checking the loading through tests or calculation/simulation and comparing them with the permissible values.
- ▶ Special requirements apply in the case of belt drives. Please contact us.

Key

- V_g = Displacement per revolution [cm³]
- Δp = Differential pressure [bar]
- n = Rotational speed [rpm]
- η_v = Volumetric efficiency
- η_{hm} = Hydraulic-mechanical efficiency
- η_t = Total efficiency ($\eta_t = \eta_v \times \eta_{hm}$)

- 1) The values are applicable:
 - for the optimum viscosity range from $\nu_{\text{opt}} = 36$ to 16 mm²/s
 - with hydraulic fluid based on mineral oils
- 2) The values apply at absolute pressure $p_{\text{abs}} = 1$ bar at suction port **S**.
- 3) The values apply at absolute pressure $p_{\text{abs}} = 0.8$ bar at suction port **S**.
- 4) Maximum rotational speed (speed limit) for increased inlet pressure p_{absolute} at suction port **S** and $V_g < V_{g \max}$, see diagram in the respective product-specific data sheets. The maximum values in the data sheets must not be exceeded.
- 5) The data are valid for values between the minimum required and maximum permissible rotational speed. Valid for external excitation (e.g. diesel engine 2 to 8 times rotary frequency; cardan shaft twice the rotary frequency). The limit value is only valid for a single pump. The load capacity of the connection parts must be considered.
- 6) Weight may vary by equipment.

Permissible input and through-drive torques

Size	NG	60	72	85	95	190	260	520			
Torque at $V_{g \max}$ and $\Delta p = 210 \text{ bar}^1$	M_{\max}	Nm	–	–	284	–	–	–			
Torque at $V_{g \max}$ and $\Delta p = 250 \text{ bar}^1$	M_{\max}	Nm	477	572	–	–	–	–			
Torque at $V_{g \max}$ and $\Delta p = 350 \text{ bar}^1$	M_{\max}	Nm	–	–	–	1045	2147	2897			
Maximum input torque on drive shaft ²⁾											
Splined shaft		S	$M_{E \max}$	Nm	630	630	630	1640	–	–	–
		ISO 3019-1	\emptyset	inch	1 1/4	1 1/4	1 1/4	–	–	–	–
		ANSI B92.1a	\emptyset	inch	–	–	–	1 3/4	–	–	–
		Z	$M_{E \max}$	Nm	–	–	–	2190	3140	5780	5793
		DIN 5480	\emptyset		–	–	–	W45	W50	W60	W80
		T	$M_{E \max}$	Nm	–	–	–	–	2670	4070	–
		ANSI B92.1a	\emptyset	inch	–	–	–	–	2	2 1/4	–
Maximum through-drive torque		$M_{D \max}$	Nm	On request	On request	On request	*)	*)	*)	On request	

▼ Distribution of torques

*) Calculation for sizes 95 to 260

$M_3 < 300 \text{ Nm}$
 $M_2 + M_3 < M_{\max 2} + 300 \text{ Nm}$

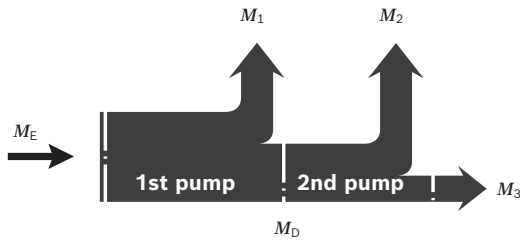

Torque at 1st pump	M_1
Torque at 2nd pump	M_2
Torque at 3rd pump	M_3
Input torque	$M_E = M_1 + M_2 + M_3$
	$M_E < M_{E \max}$
Through-drive torque	$M_D = M_2 + M_3$
	$M_D < M_{D \max}$

1) Efficiency not considered
 2) For drive shafts with no radial force

Examples of control devices

Circuit diagram example A20V(N)O size 60, 72 and 85 DFR

Controller description see data sheet 92703 and 92735

▼ Circuit diagram DFR size 60

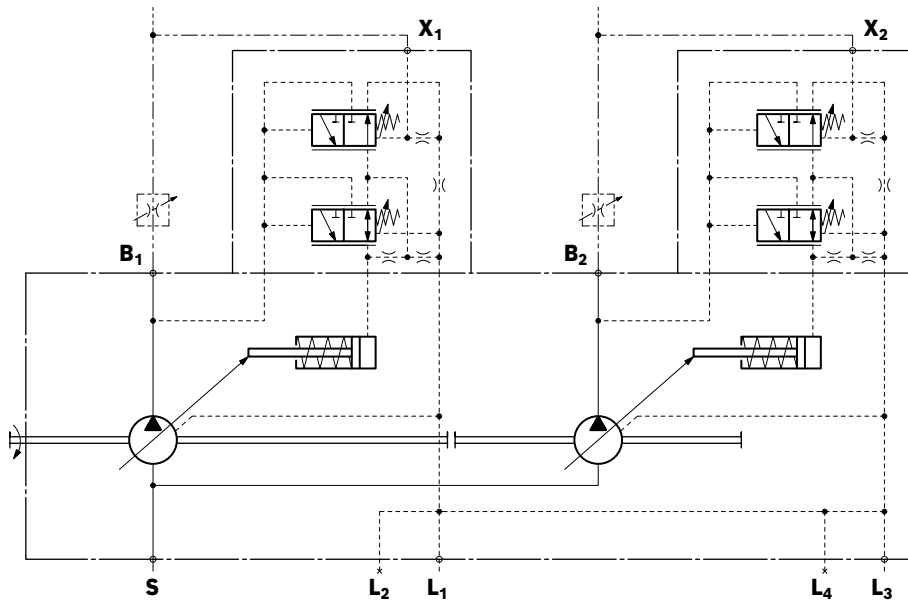

Circuit diagram example A20VO size 95 to 260 LE2D

See data sheet 92500 for controller description

▼ Circuit diagram A20V(L)O size 190 LE2D

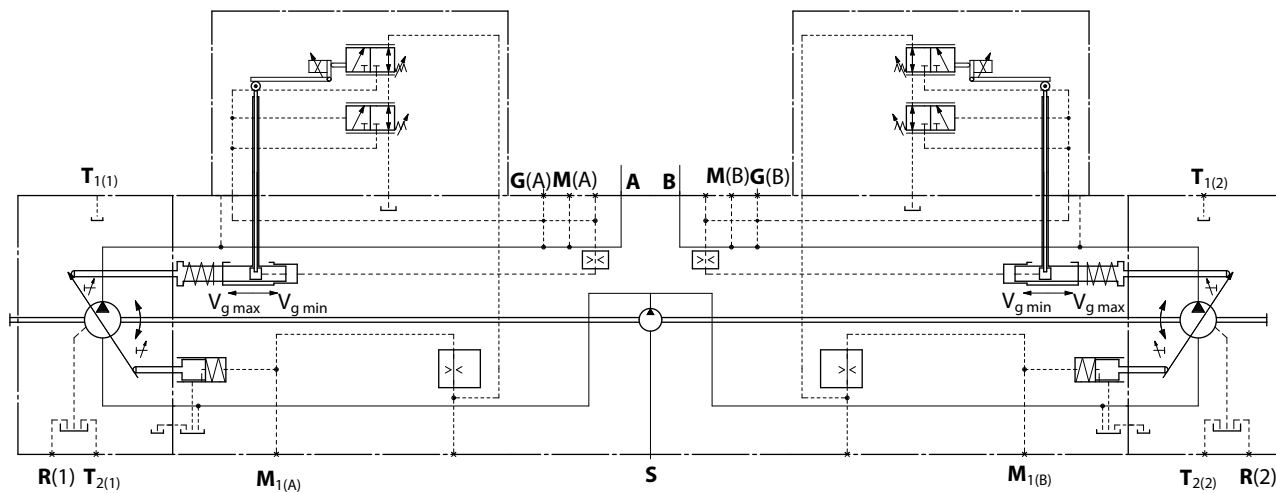

Circuit diagram example A20VO size 520 LR2G

See data sheet 92064 for controller description

▼ **Circuit diagram LR2G size 520**

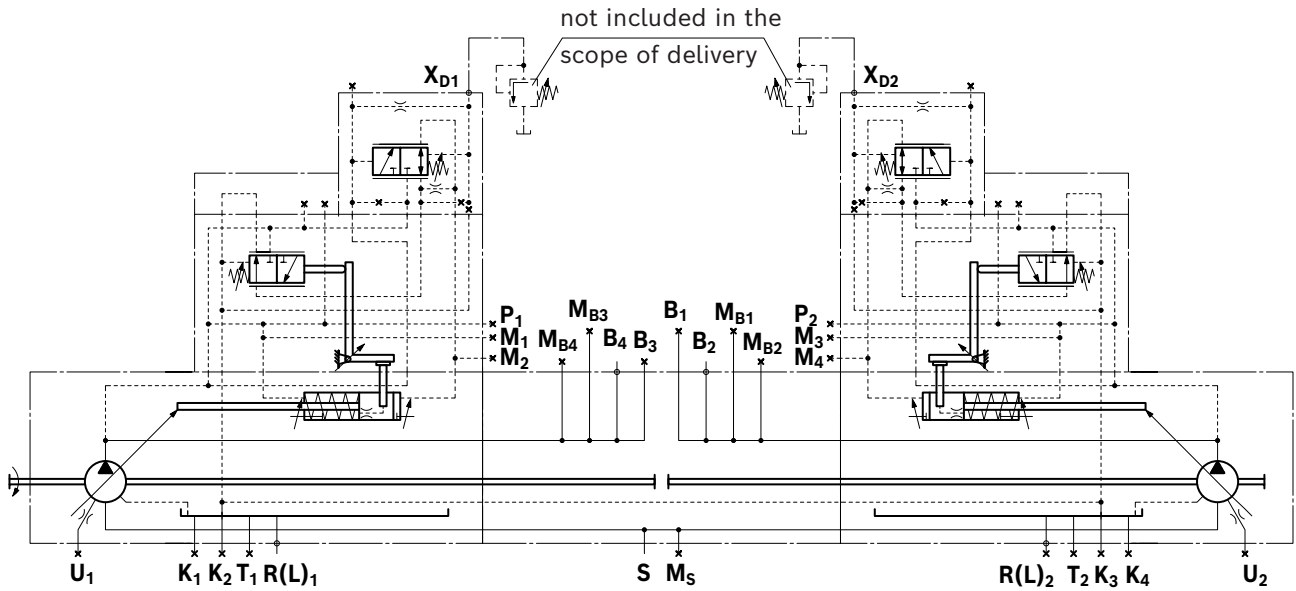

Circuit diagram example A20VO size 520 HS5P

See data sheet 92076 for controller description

▼ **Circuit diagram HS5P size 520**

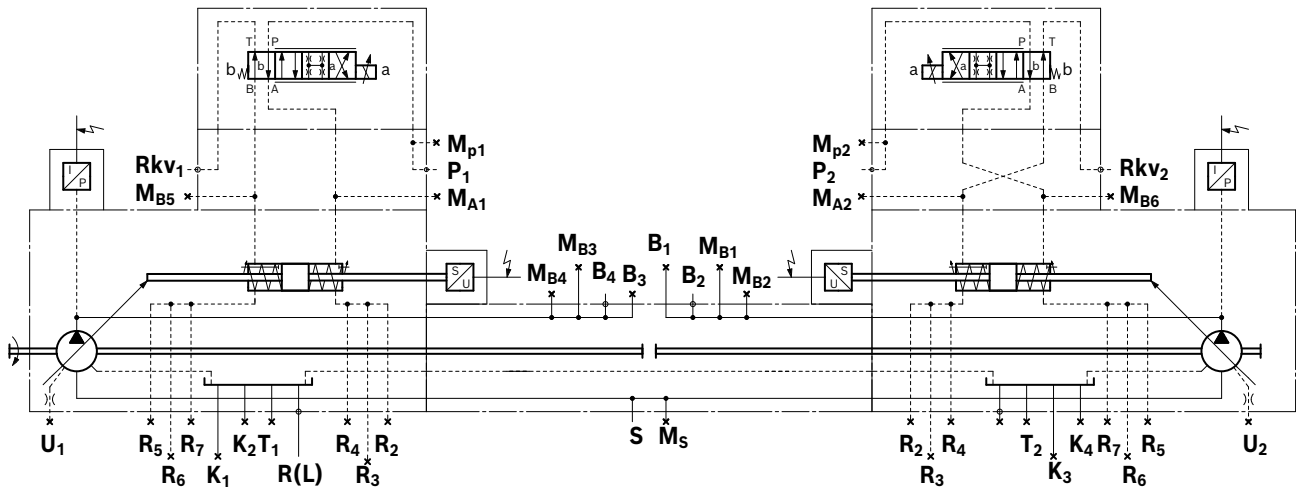

Notice regarding direction of rotation where applicable

Dimensions of nominal size 60, 72 and 85 without control device

See data sheets 92703 and 92735 for further dimensions of the control devices and their selection

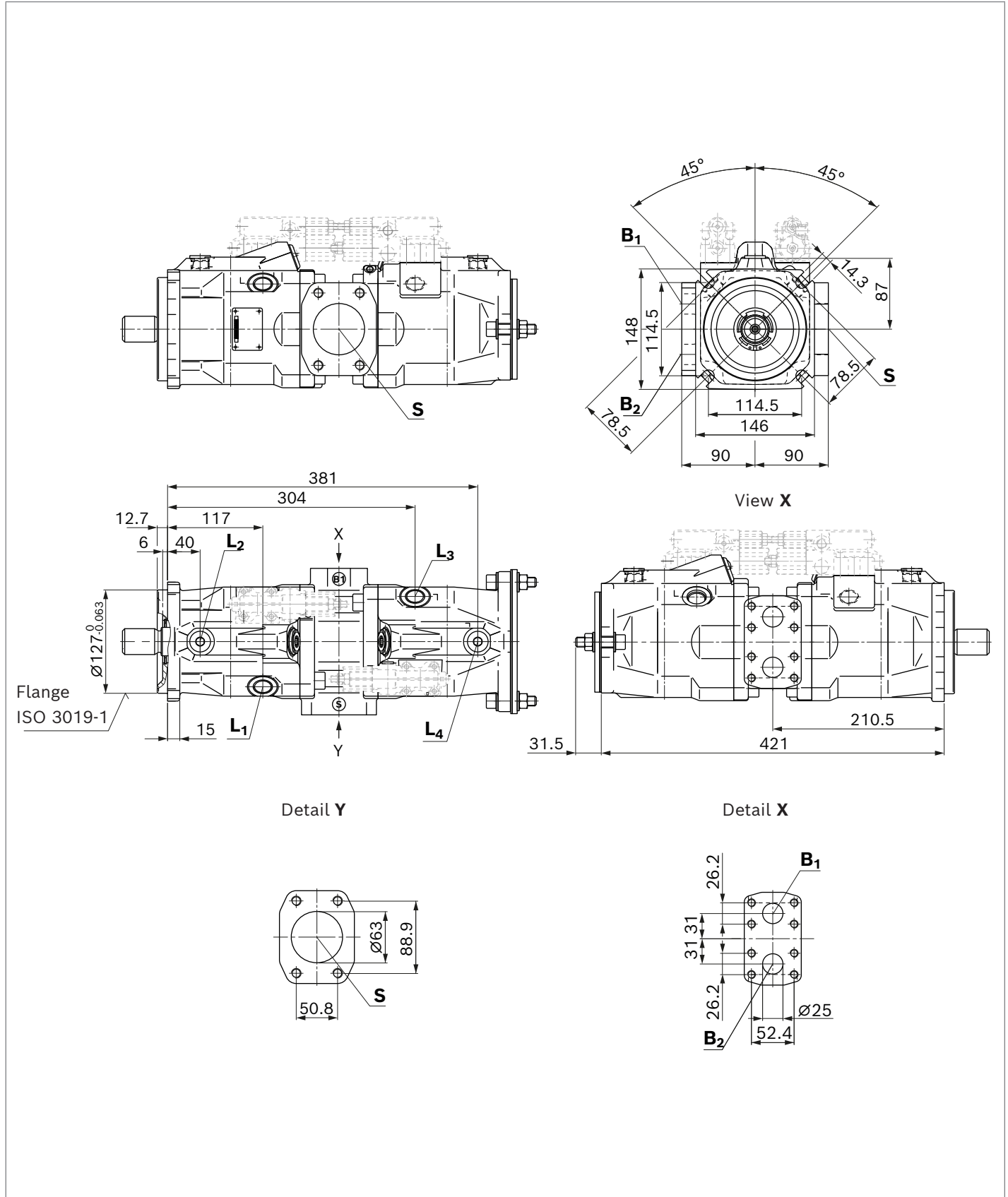

▼ **Splined shaft ISO 3019-1**

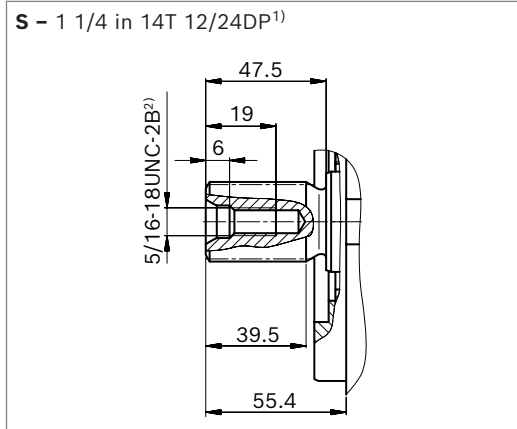

Ports	Standard	Size	p_{\max} [bar] ³⁾	State ⁶⁾	
S	Suction port (standard pressure series) Fastening thread	ISO 6162-1 DIN 13	2 1/2 in M12 × 1.75; 20 deep	5	O
NG85 B₁, B₂	Pressure port (high-pressure series) Fastening thread	ISO 6162-1 DIN 13	1 in M10 × 1.5; 17 deep	250	O
NG60, 72 B₁, B₂	Pressure port (high-pressure series) Fastening thread	ISO 6162-1 DIN 13	1 in M10 × 1.5; 17 deep	315	O
L₁, L₂, L₃, L₄	Drain port	DIN 3852 ⁴⁾	7/8-14UNF-2B; 13 deep	2	X ⁵⁾

1) Involute spline according to ANSI B92.1a, 30° pressure angle, flat root, side fit, tolerance class 5
 2) Thread according to ASME B1.1
 3) Depending on the application, momentary pressure peaks can occur. Keep this in mind when selecting measuring devices and fittings.
 4) The countersink may be deeper than specified in the standard.
 5) Depending on the installation position, **L₁, L₂, L₃**, or **L₄** must be connected (also see installation instructions in the respective product-specific data sheets)
 6) O = Must be connected (plugged on delivery)
 X = Plugged (in normal operation)

Dimensions of size 95 without control device

See data sheet 92500 for further dimensions of the control devices and their selection

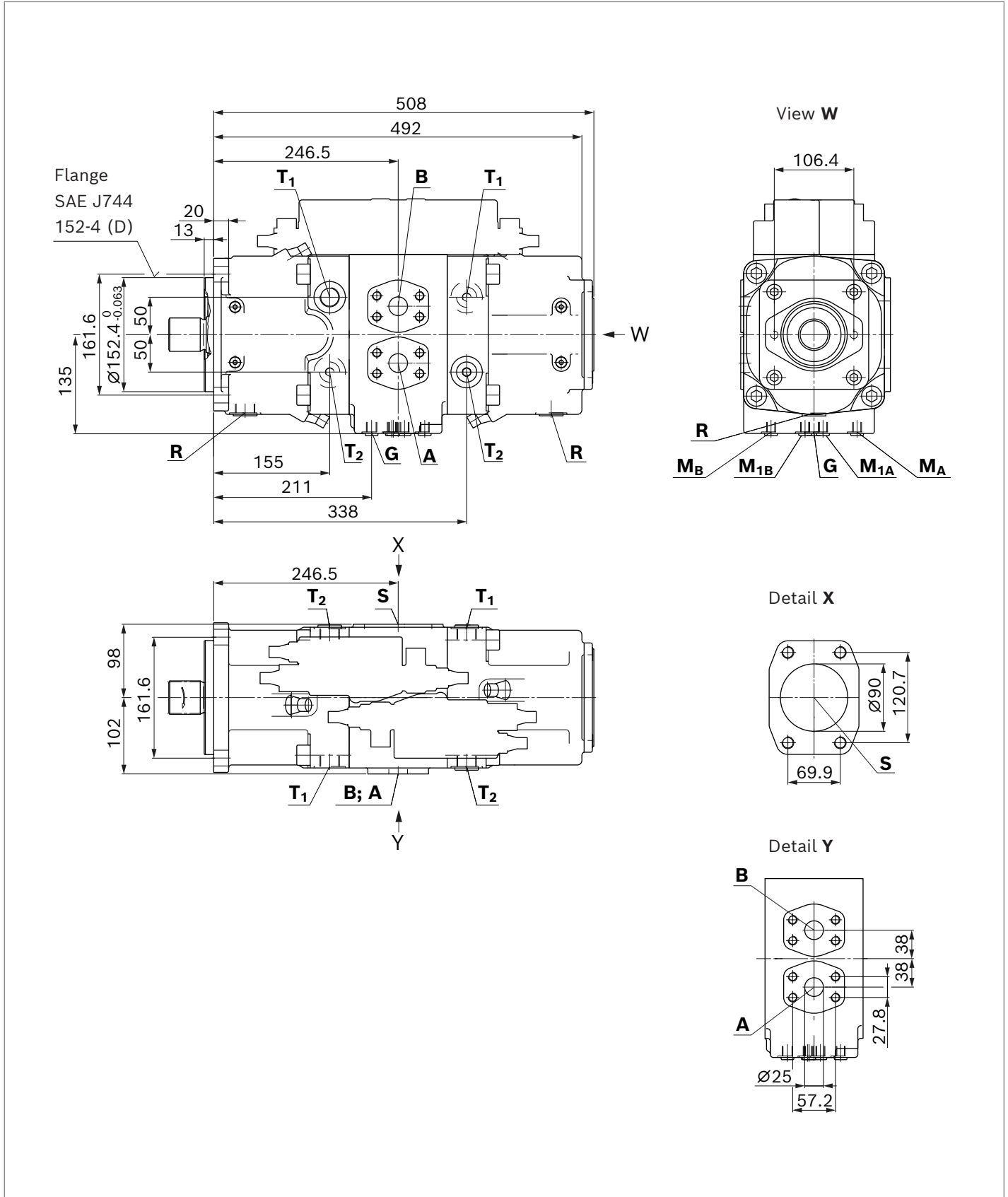

▼ **Splined shaft SAE J744**

S – 1 3/4 in 13T 8/16DP¹⁾

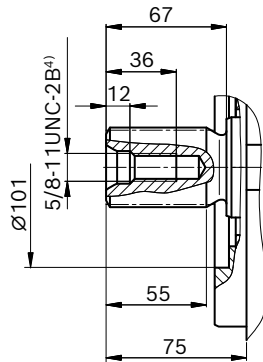

▼ **Splined shaft DIN 5480**

Z – W45 × 2 × 21 × 9g

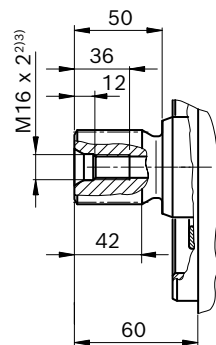

Ports		Standard	Size	p_{\max} [bar] ⁶⁾	State ⁹⁾
S	Suction port (standard pressure series) Fastening thread	SAE J518 ⁵⁾ DIN 13	3 1/2 in M16 × 2; 24 deep	30	O
A, B	Pressure port (high-pressure series) Fastening thread	SAE J518 ⁵⁾ DIN 13	1 in M12 × 1.75; 17 deep	400	O
T₁, T₂	Drain port	DIN 3852 ⁷⁾	M26 × 1.5; 16 deep	10	X ⁸⁾
M_{1(A)}, M_{1(B)}	Measuring port, control pressure	DIN 3852 ⁷⁾	M12 × 1.5; 12 deep	400	X
M_A, M_B	Measuring port working pressure A/B	DIN 3852 ⁷⁾	M12 × 1.5; 12 deep	400	X
R	Air bleed port	DIN 3852 ⁷⁾	M27 × 2; 16 deep	10	O ⁸⁾
G	Control pressure port (controller) ¹⁰⁾	DIN 3852 ⁷⁾	M14 × 1.5; 12 deep	40	X

1) Involute spline according to ANSI B92.1a, 30° pressure angle, flat root, side fit, tolerance class 5
 2) Center bore according to DIN 332
 3) Thread according to DIN 13
 4) Thread according to ASME B1.1
 5) Metric fastening thread is a deviation from standard.
 6) Depending on the application, momentary pressure peaks can occur. Keep this in mind when selecting measuring devices and fittings.

7) The countersink may be deeper than specified in the standard.
 8) Depending on the installation position, **T₁**, **T₂**, or **R** must be connected (also see installation instructions in the respective product-specific data sheets)
 9) O = Must be connected (plugged on delivery)
 X = Plugged (in normal operation)
 10) For version with stroke limiter (H..., U2, U6), HD, and EP (otherwise connection **G** plugged).

Dimensions of size 190 with charge pump, without control device

See data sheet 92500 for further dimensions of the control devices and their selection

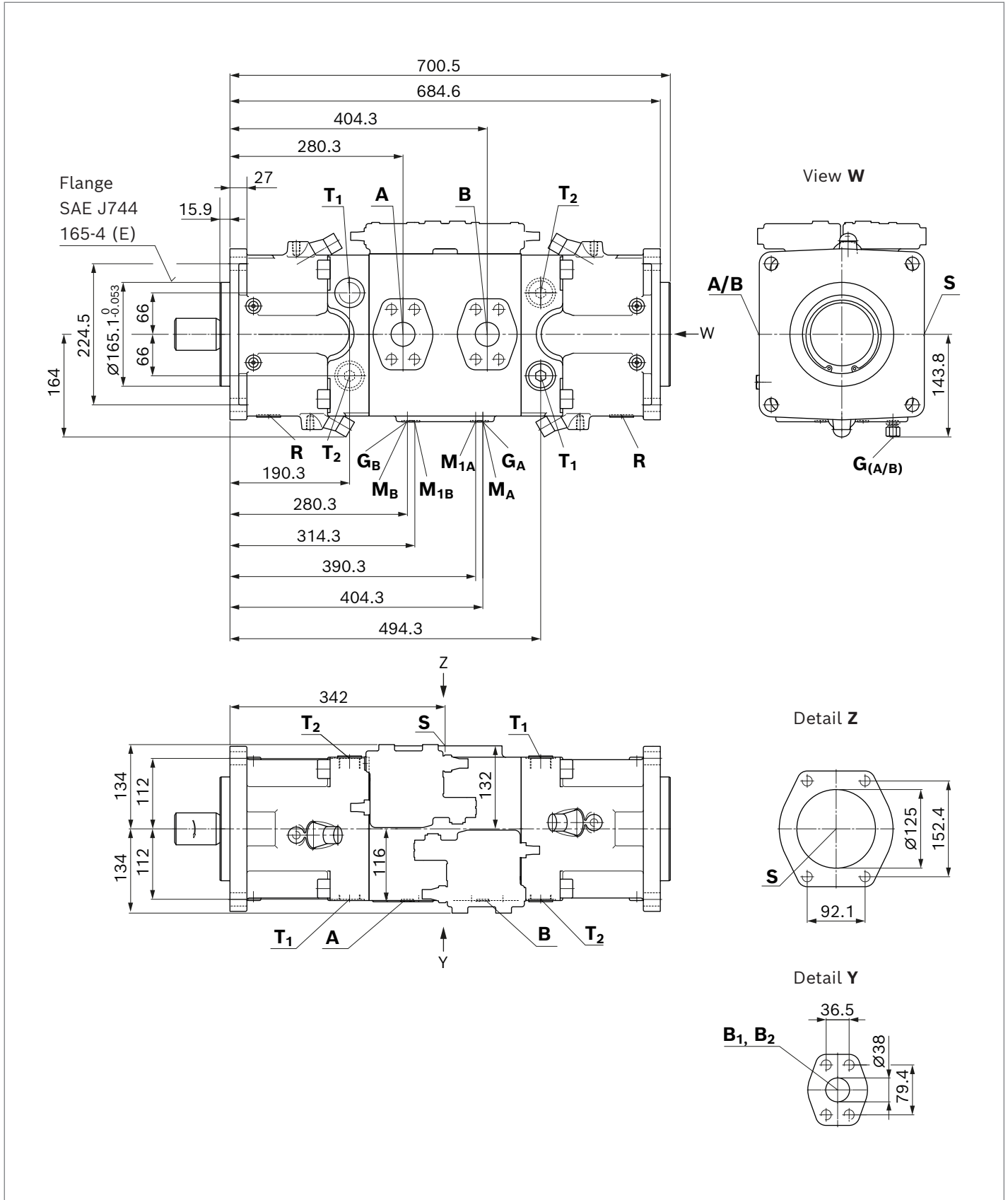

▼ **Splined shaft SAE J744**

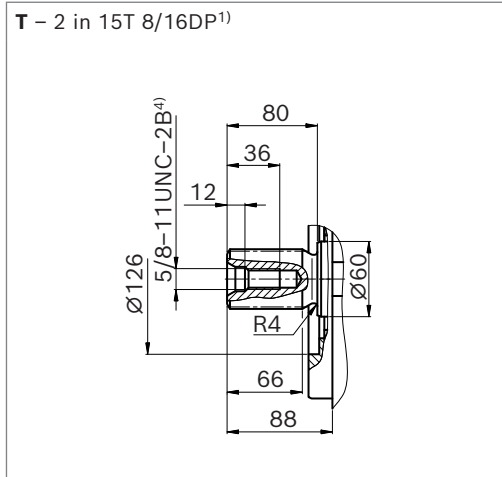

▼ **Splined shaft DIN 5480**

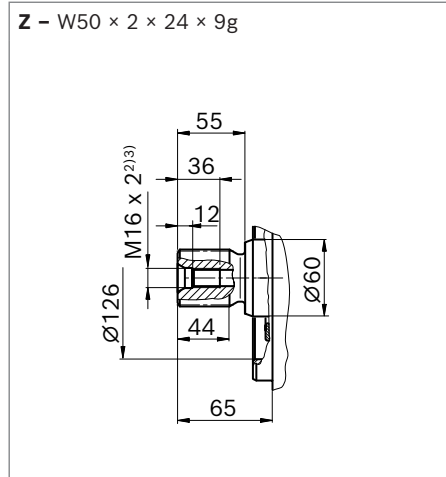

Ports		Standard	Size	p_{\max} [bar] ⁶⁾	State ⁹⁾
S	Suction port (standard pressure series) Fastening thread	SAE J518 ⁵⁾ DIN 13	5 in M16 × 2; 23 deep	30	O
A, B	Pressure port (high-pressure series) Fastening thread	SAE J518 ⁵⁾ DIN 13	1 1/2 in M16 × 2; 21 deep	400	O
T₁, T₂	Drain port	DIN 3852 ⁷⁾	M33 × 2; 18 deep	10	X ⁸⁾
M_{1(A)}, M_{1(B)}	Measuring port, control pressure	DIN 3852 ⁷⁾	M12 × 1.5; 12 deep	400	X
M_A, M_B	Measuring port working line A/B	DIN 3852 ⁷⁾	M12 × 1.5; 12 deep	400	X
R	Air bleed port	DIN 3852 ⁷⁾	M33 × 2; 16 deep	10	O ⁸⁾
G_A, G_B	Control pressure port (controller) ¹⁰⁾	DIN 3852	M14 × 1.5; 12 deep	40	X

1) Involute spline according to ANSI B92.1a, 30° pressure angle, flat root, side fit, tolerance class 5
 2) Center bore according to DIN 332
 3) Thread according to DIN 13
 4) Thread according to ASME B1.1
 5) Metric fastening thread is a deviation from standard.
 6) Depending on the application, momentary pressure peaks can occur. Keep this in mind when selecting measuring devices and fittings.

7) The countersink may be deeper than specified in the standard.
 8) Depending on the installation position, **T₁**, **T₂**, or **R** must be connected (also see installation instructions in the respective product-specific data sheets)
 9) O = Must be connected (plugged on delivery)
 X = Plugged (in normal operation)
 10) For version with stroke limiter (H..., U2, U6), HD, and EP (otherwise connection **G** plugged).

Dimensions of size 260 with charge pump, without control device

See data sheet 92500 for further dimensions of the control devices and their selection

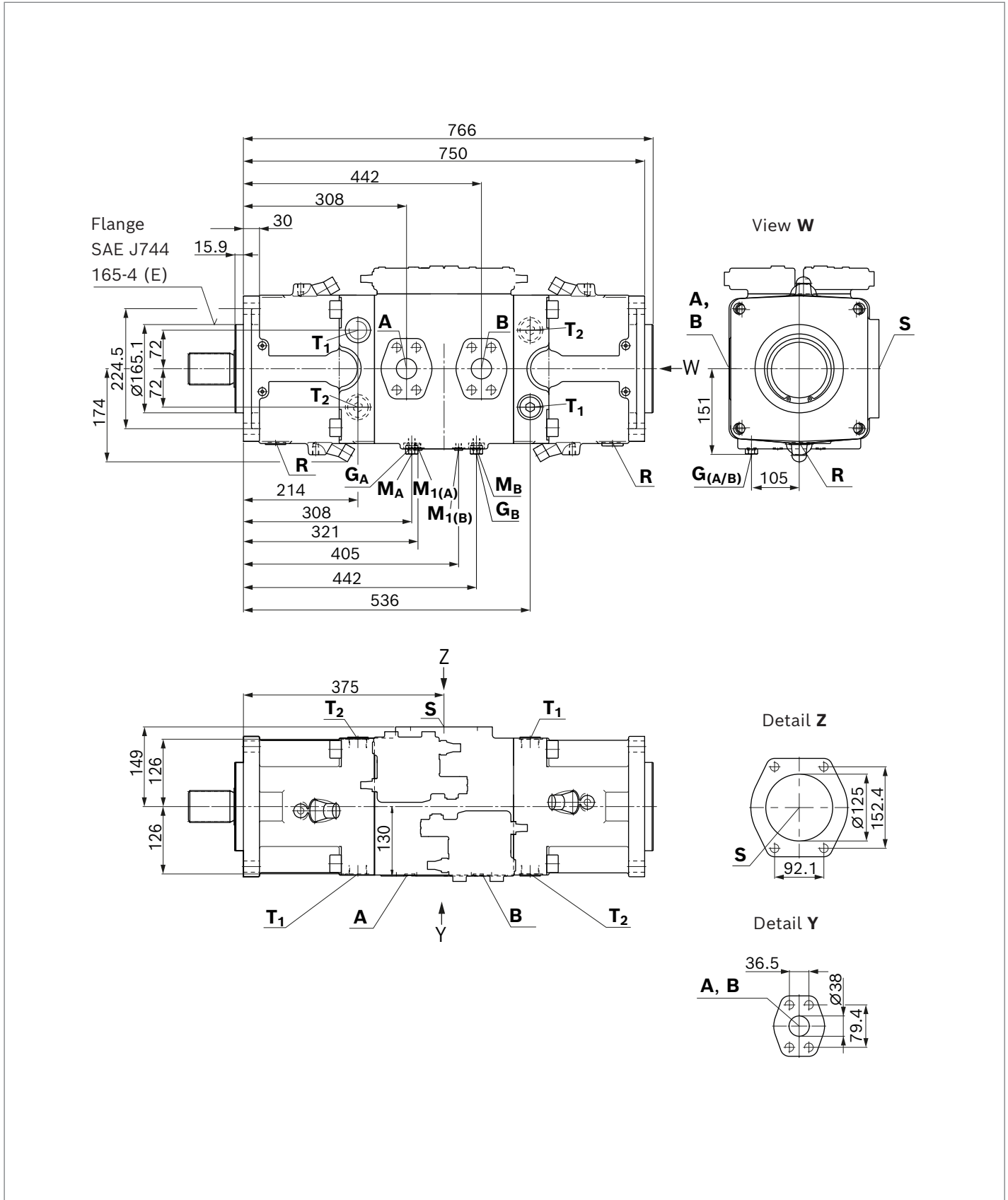

▼ **Splined shaft SAE J744**

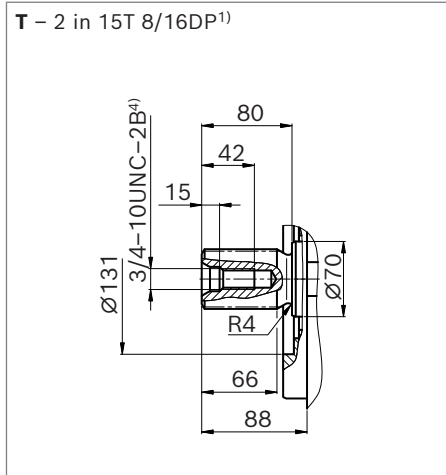

▼ **Splined shaft DIN 5480**

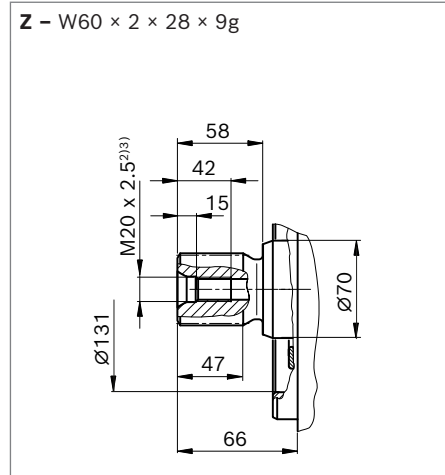

Ports		Standard	Size	p_{\max} [bar] ⁶⁾	State ⁹⁾
S	Suction port (standard pressure series) Fastening thread	SAE J518 ⁵⁾ DIN 13	5 in M16 × 2; 23 deep	30	O
A, B	Pressure port (high-pressure series) Fastening thread	SAE J518 ⁵⁾ DIN 13	1 1/2 in M16 × 2; 21 deep	400	O
T₁, T₂	Drain port	DIN 3852 ⁷⁾	M33 × 2; 18 deep	10	X ⁸⁾
M_{1(A)}, M_{1(B)}	Measuring port, control pressure	DIN 3852 ⁷⁾	M12 × 1.5; 12 deep	400	X
M_A, M_B	Measuring port working pressure A/B	DIN 3852 ⁷⁾	M12 × 1.5; 12 deep	400	X
R	Air bleed port	DIN 3852 ⁷⁾	M33 × 2; 16 deep	10	O ⁸⁾
G_A, G_B	Control pressure port (controller) ¹⁰⁾	DIN 3852	M14 × 1.5; 12 deep	40	X

1) Involute spline according to ANSI B92.1a, 30° pressure angle, flat root, side fit, tolerance class 5
 2) Center bore according to DIN 332
 3) Thread according to DIN 13
 4) Thread according to ASME B1.1
 5) Metric fastening thread is a deviation from standard.
 6) Depending on the application, momentary pressure peaks can occur. Keep this in mind when selecting measuring devices and fittings.

7) The countersink may be deeper than specified in the standard.
 8) Depending on the installation position, **T₁**, **T₂**, or **R** must be connected (also see installation instructions in the respective product-specific data sheets)
 9) O = Must be connected (plugged on delivery)
 X = Plugged (in normal operation)
 10) For version with stroke limiter (H..., U2, U6), HD, and EP (otherwise connection **G** plugged).

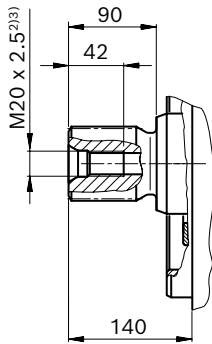
▼ **Splined shaft DIN 5480**Z – W80 × 3 × 25 × 9g¹⁾

Ports		Standard	Size	p_{\max} [bar] ⁵⁾	State ⁸⁾
S	Suction port (standard pressure series) Fastening thread	SAE J518 ⁴⁾ DIN 13	5 in M16 × 2; 24 deep	30	O
B₁ to B₃	Pressure port (high-pressure series) Fastening thread	SAE J518 ⁴⁾ DIN 13	2 in M20 × 2.5; 24 deep	400	O
B₂ to B₄	Auxiliary port (high-pressure series) Fastening thread	SAE J518 ⁴⁾ DIN 13	2 in M20 × 2.5; 24 deep	400	X
K₁ to K₄	Flushing port	DIN 3852 ⁶⁾	M48 × 2; 22 deep	5	X ⁷⁾
R(L)₁, R(L)₂, T₁	Filling and air bleed port	DIN 3852 ⁶⁾	M48 × 2; 22 deep	5	X ⁷⁾
T₂	Drain	DIN 3852 ⁶⁾	M48 × 2; 22 deep	5	X ⁷⁾
M₁ to M₄	Measuring port stroking chamber pressure	DIN 3852 ⁶⁾	M18 × 1.5; 12 deep	350	X
M_{B1} to M_{B4}	Measuring port working pressure	DIN 3852 ⁶⁾	M18 × 1.5; 12 deep	400	X
M_{St1}, M_{St2}	Pilot pressure measuring port	DIN 3852 ⁶⁾	M16 × 2; 12 deep	30	X
P_{st1}, P_{st2}	Pilot pressure port	DIN 3852 ⁶⁾	M14 × 1.5; 12 deep	50	X
U	Flushing port for bearing flushing	DIN 3852 ⁶⁾	M14 × 1.5; 12 deep	5	X

1) Splined shaft according to DIN 5480

2) Center bore according to DIN 332

3) Thread according to DIN 13

4) Metric fastening thread is a deviation from standard.

5) Depending on the application, momentary pressure peaks can occur.
Keep this in mind when selecting measuring devices and fittings.

6) The countersink may be deeper than specified in the standard.

7) Depending on the installation position, **T₁**, **T₂** or **R(L)** must be connected (also see installation instructions in the respective product-specific data sheets)8) O = Must be connected (plugged on delivery)
X = Plugged (in normal operation)

Dimensions through drive nominal size 60, 72, 85 and 520

Flange ISO 3019-1 (SAE)		Hub for splined shaft ¹⁾		Availability across sizes					Code	
Diameter	Mounting ²⁾	Diameter		60, 72, 85	95	190	260	520		
82-2 (A)		5/8 in	9T 16/32DP	●	see page 25				○	K01
		3/4 in	11T 16/32DP	●	-	-	-	-	-	K52

● = Available ○ = On request

▼ **82-2**

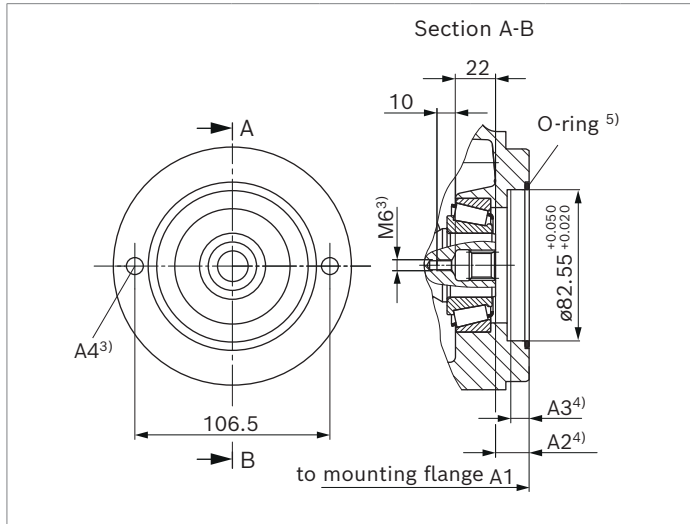

K01 (SAE J744 16-4 (A))	NG	A1	A2	A3	A4 ³⁾⁶⁾
	60, 72 ,	421	18.3	10	M10×1.5;
	85				16 deep

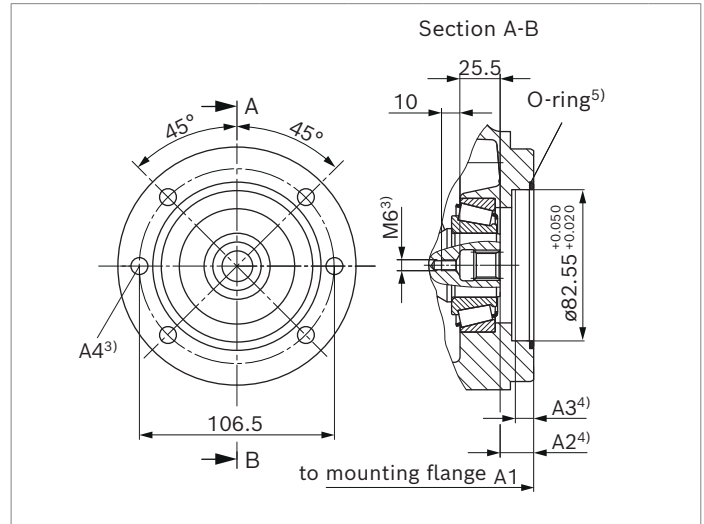

K52 (SAE J744 19-4 (A-B))	NG	A1	A2	A3	A4 ³⁾⁶⁾
	60, 72 ,	433.7	17.7	10	M10×1.5;
	85				16 deep

- 1) According to ANSI B92.1a, 30° pressure angle, flat root, side fit, tolerance class 5
- 2) Mounting holes pattern viewed on through drive with control at top
- 3) Thread according to DIN 13.
- 4) Minimum dimensions
- 5) O-ring seal is included in the scope of delivery.
- 6) Design recommended according to VDI 2230, screw quality 8.8 according to ISO 898-1

Through drive dimensions sizes 95, 190, and 260

Flange ISO 3019-1 (SAE)		Hub for splined shaft ¹⁾		Availability across sizes					Code
Diameter	Mounting ²⁾	Diameter		60, 72, 85	95	190	260	520	
82-2 (A)		5/8 in	9T 16/32DP	-	●	-	-	-	K01
				-	-	●	●	-	
101-2 (B)		7/8 in	13T 16/32DP	-	●	-	-	-	K02
				-	-	●	●	-	

● = Available ○ = On request

▼ **82-2**

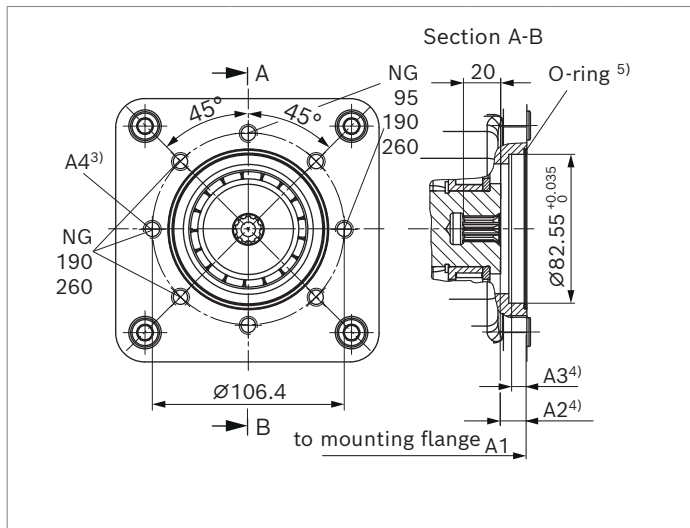

K01 (SAE J744 16-4 (A))	NG	A1	A2	A3	A4 ³⁾ 7)
	95	510	14.5	8	M10×1.5; 12.5 deep
	190	709.6	11	11	M10×1.5; 15 deep
	260	787.2	13.5	10	M10×1.5; 15 deep

▼ **101-2**

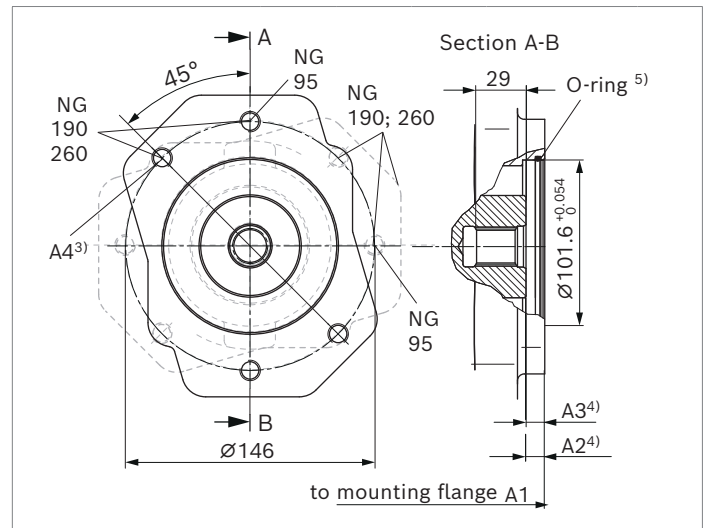

K02 (SAE J744 22-4 (B))	NG	A1	A2	A3	A4 ³⁾ 7)
	95	515	10.8	12	M12×1.75; 15 deep
	190	725.6	11	13	M12×1.75; 15 deep
	260	791.2	11	11	M12×1.75; 15 deep

- 1) According to ANSI B92.1a, 30° pressure angle, flat root, side fit, tolerance class 5
- 2) Mounting holes pattern viewed on through drive with control at top
- 3) Thread according to DIN 13.
- 4) Minimum dimensions
- 5) O-ring seal is included in the scope of delivery.
- 6) Installation rotated by 90° is possible.
Please specify mounting orientation in plain text.
- 7) Design recommended according to VDI 2230, screw quality 8.8 according to ISO 898-1

Through drive dimensions sizes 95, 190, and 260

Flange ISO 3019-1 (SAE)		Hub for splined shaft ¹⁾		Availability across sizes					Code
Diameter	Mounting ²⁾	Diameter		60, 72, 85	95	190	260	520	
101-2 (B)		1 in	15T 16/32DP	-	●	-	-	-	K04
				-	-	●	●	-	

● = Available ○ = On request

▼ 101-2

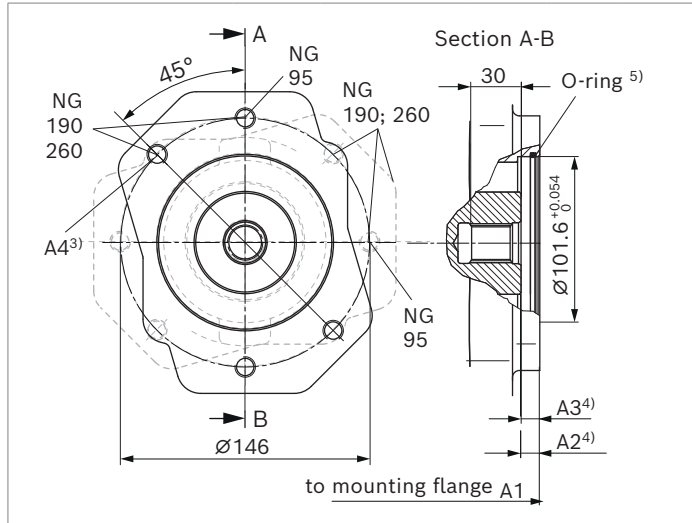

K04 (SAE J744 22-4 (B))	NG	A1	A2	A3	A4 ³⁾⁷⁾
	95	515	21.5	12	M12×1.75; 15 deep
	190	725.6	11	13	M12×1.75; 15 deep
	260	791.2	11	11	M12×1.75; 15 deep

1) According to ANSI B92.1a, 30° pressure angle, flat root, side fit, tolerance class 5

2) Mounting holes pattern viewed on through drive with control at top

3) Thread according to DIN 13.

4) Minimum dimensions

5) O-ring seal is included in the scope of delivery.

6) Installation rotated by 90° is possible.

Please specify mounting orientation in plain text.

7) Design recommended according to VDI 2230, screw quality 8.8 according to ISO 898-1

Through drive dimensions sizes 60 and 520

Flange ISO 3019-1 (SAE)		Hub for splined shaft ¹⁾		Availability across sizes					Code
Diameter	Mounting ²⁾	Diameter		60, 72, 85	95	190	260	520	
101-2 (B)		7/8 in	13T 16/32DP	●	-	-	-	-	K68
		7/8 in	13T 16/32DP	-	-	-	-	○	

● = Available ○ = On request

▼ 101-2

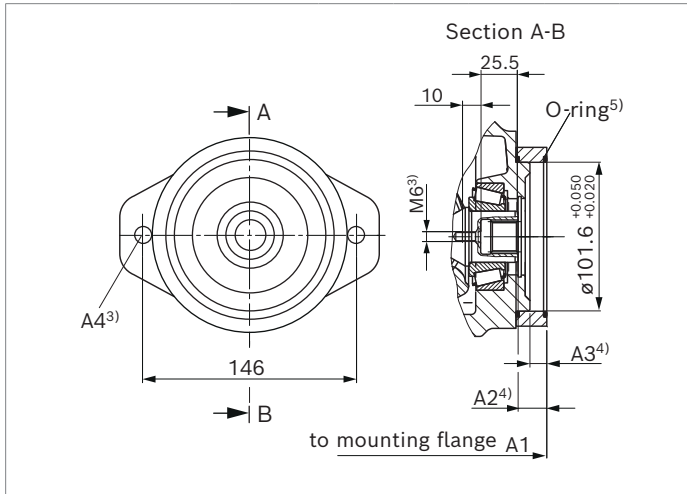

K68 (SAE J744 22-4 (B))	NG	A1	A2 ⁴⁾	A3 ⁴⁾	A4 ³⁾⁶⁾
	60, 72 , 85	442	19	11.5	M12×1.75; continuous

▼ 101-2

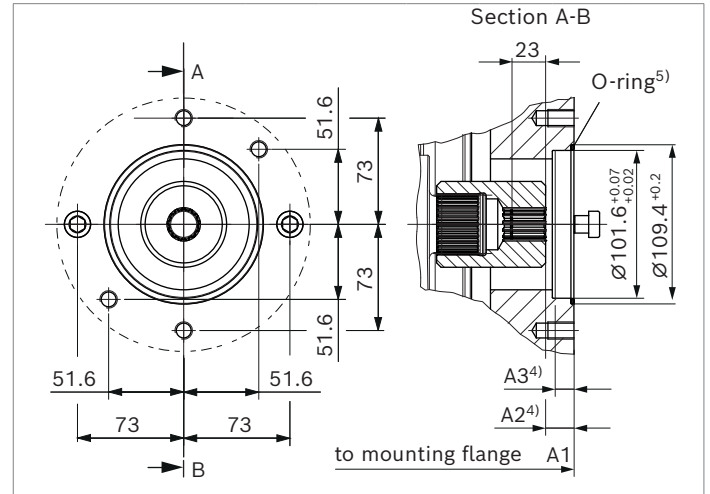

K68 (SAE J744 22-4 (B))	NG	A1	A2 ⁴⁾	A3 ⁴⁾	A4 ³⁾⁶⁾
	520	1105.5	19.6	13	M12×1.75; 18 deep

- 1) According to ANSI B92.1a, 30° pressure angle, flat root, side fit, tolerance class 5
- 2) Mounting holes pattern viewed on through drive with control at top
- 3) Thread according to DIN 13.
- 4) Minimum dimensions
- 5) O-ring seal is included in the scope of delivery.
- 6) Design recommended according to VDI 2230, screw quality 8.8 according to ISO 898-1

Through drive dimensions sizes 95, 190, and 260

Flange ISO 3019-1 (SAE)		Hub for splined shaft ¹⁾ Diameter	Availability across sizes					Code
Diameter	Mounting ²⁾		60, 72, 85	95	190	260	520	
127-2 (C)	 or	1 1/4 in 14T 12/24DP	-	●	●	-	-	K07
			-	-	-	●	-	

● = Available ○ = On request

▼ 127-2

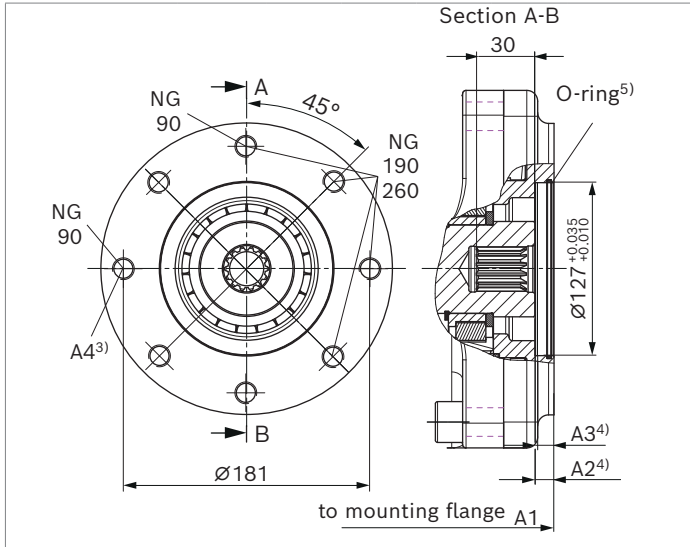

K07 (SAE J744 16-4 (A))	NG	A1	A2 ⁴⁾	A3 ⁴⁾	A4 ³⁾⁷⁾
95	515	21.5	13.5	M16×2; continuous	
190	721.6	28.3	13	M16×2; 20 deep	
260	787	13.6	13	M16×2; 20 deep	

- 1) According to ANSI B92.1a, 30° pressure angle, flat root, side fit, tolerance class 5
- 2) Mounting holes pattern viewed on through drive with control at top
- 3) Thread according to DIN 13.
- 4) Minimum dimensions
- 5) O-ring seal is included in the scope of delivery.
- 6) Installation rotated by 90° is possible.
Please specify mounting orientation in plain text.
- 7) Design recommended according to VDI 2230, screw quality 8.8 according to ISO 898-1

Through drive dimensions size 520

Flange ISO 3019-1 (SAE)		Hub for splined shaft ¹⁾		Availability across sizes					Code
Diameter	Mounting ²⁾	Diameter		60, 72, 85	95	190	260	520	
127-2 (C)		1 1/4 in	14T 12/24DP	-	-	-	-	●	K07

● = Available ○ = On request

▼ **127-2**

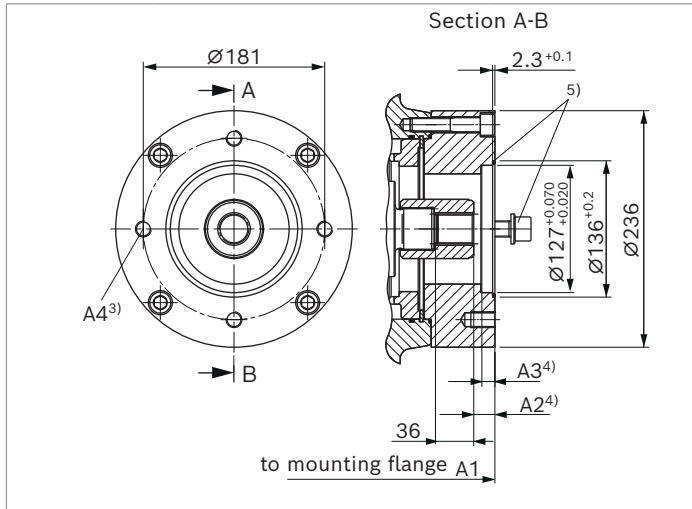

K07	NG	A1	A2	A3	A4 ³⁾⁶⁾
(SAE J744 16-4 (A))					
	520	1105.5	21.1	13	M16×2; 24 deep

- 1) According to ANSI B92.1a, 30° pressure angle, flat root, side fit, tolerance class 5
- 2) Mounting holes pattern viewed on through drive with control at top
- 3) Thread according to DIN 13.
- 4) Minimum dimensions
- 5) Fixing screws and O-ring seal are included in the scope of delivery.
- 6) Design recommended according to VDI 2230, screw quality 8.8 according to ISO 898-1

Overview of mounting options

Through drive			Mounting options – 2nd pump			
Flange ISO 3019-1	Hub for splined shaft	Code	A10V(S)O/5x NG (shaft)	A10VO/31 NG (shaft)	A11VO/10 NG (shaft)	External gear pump
82-2 (A)	5/8 in	K01	10 (U), 18 (U)	18 (U)	–	AZPF
	3/4 in	K52	10 (S), 18 (S, R)	18 (S, R)	–	AZPF
101-2 (B)	7/8 in	K02	28 (S), 45 (U)	28 (S), 45 (U)	–	AZPN/AZPG
		K68	28 (S, R) 45 (U, W)	28 (S, R) 45 (U, W)	–	AZPN/AZPG
	1 in	K04	45 (S), 60 (U)	45 (S)	40 (S)	–
127-2 (C)	1 1/4 in	K07	60 (S) ¹⁾ , 85 (U)	71 (S), 100 (U)	60 (S)	–

Combination pumps A20V(N)O + A10VO

By using combination pumps, it is possible to have independent circuits without the need for splitter gearboxes.

When ordering combination pumps the type designations for the 1st and the 2nd pump must be joined by a "+".

Order example:

A20VO60DRF1/10R-VSD24K01+

A10VO18DRF/53R-VSC12N00

If no further pumps are to be mounted at the factory, the simple type designation is sufficient.

A tandem pump, with two pumps of equal size, is permissible without additional supports, assuming that the dynamic mass acceleration does not exceed max. 10 g (= 98.1 m/s²).

For combination pumps consisting of more than two pumps, a calculation of the mounting flange regarding the permissible mass torque is required (please contact us).

Through drives are plugged with a **non-pressure-resistant** cover. Therefore, single pumps must be equipped with a pressure-resistant cover before commissioning.

Through drives can also be ordered with a pressure-resistant cover, please specify in plain text.

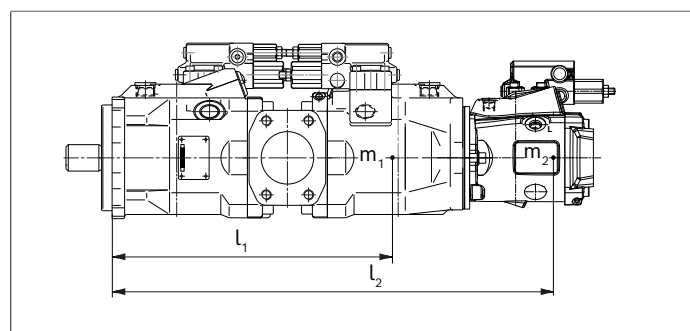

m_1, m_2, \dots Weight of pump [kg]

l_1, l_2, \dots Distance from center of gravity [mm]

$$T_m = (m_1 \times l_1 + m_2 \times l_2 + \dots) \times \frac{1}{102} \text{ [Nm]}$$

Calculation for multiple pumps

l_1 = Front pump distance from center of gravity (values from "Permissible moments of inertia" table)

l_2 = Dimension "A1" from through drive drawings (page to + l_1 of the 2nd pump)

l_3 = Dimension "A1" from through drive drawings (page to) of the 1st pump + "A1" of the 2nd pump + l_1 of the 3rd pump

Permissible moments of inertia

Size			60, 72, 85	95	190	260	520
static	T_m	Nm	137				
dynamic at 10 g (98.1 m/s ²)	T_m	Nm	1370			on request	
Weight without through drive N00 approx.	m	kg	44	107	213	275	720
Weight with through drive K..	m	kg	49.8	110	222	284	725
Distance, center of gravity without through drive N00	l_1	mm	–	240	335	370	495
Distance, center of gravity with through drive K..	l_1	mm	213	246	350	383	500

¹⁾ A10VO 60 with 4-bolt flange can only be mounted on A11V(L)O 190 and 260.

Installation instructions

General

The axial piston unit must be filled with hydraulic fluid and air bled during commissioning and operation. This must also be observed during longer standstills, as the axial piston unit can empty itself via the hydraulic lines.

Particularly in the installation position "drive shaft upwards," filling and air bleeding must be carried out completely as there is e.g. a danger of dry running.

The leakage in the housing area must be drained to the reservoir through the highest drain port (**T₁**, **T₂**, **R(L)₁**, **R(L)₂** or **L₁**, **L₂**, **L₃**, **L₄**).

For combination pumps, the leakage must be drained off at each single pump.

If a shared drain line is used for several units, make sure that the respective case pressure in each unit is not exceeded. The shared drain line must be dimensioned to ensure that the maximum permissible case pressure of all connected units is not exceeded in any operating condition, particularly at cold start. If this is not possible, separate drain line must be laid.

To prevent the transmission of structure-borne noise, use elastic elements to decouple all connecting lines from all vibration-capable components (e.g. reservoir, frame parts). Under all operating conditions, the suction lines and the drain lines must flow into the reservoir below the minimum fluid level. The permissible suction height h_s results from the total pressure loss. However, it must not be higher than $h_{s \max} = 800 \text{ mm}$.

The minimum suction pressure at port **S** must also not fall below 0.8 bar absolute (without charge pump) or 0.6 bar absolute (with charge pump) during operation and during a cold start.

When designing the reservoir, ensure that there is adequate distance between the suction line and the drain line. We recommend using a baffle (baffle plate) between suction line and drain line. A baffle improves the air separation ability as it gives the hydraulic fluid more time for desorption. Apart from that, this prevents the heated return flow from being drawn directly back into the suction line. The suction port must be supplied with air-free, calmed and cooled hydraulic fluid.

Notice

- ▶ In certain installation positions, an influence on the adjustment or control can be expected. Gravity, dead weight and case pressure can cause minor characteristic shifts and changes in actuating time.
- ▶ Port **F** is part of the external piping and must be provided on the customer side to make filling and air bleeding easier.

Installation position

See the following examples **1** to **19**.

Further installation positions are available upon request.

Recommended installation position: **1**, **2** or **5** to **8**.

Key	
F	Filling / air bleeding
R(L)₁ , R(L)₂	Filling / air bleeding
S	Suction port
T₁ , T₂ L₁ , L₂ , L₃ , L₄	Drain port
SB	Baffle (baffle plate)
$h_{t \min}$	Minimum required immersion depth (200 mm)
h_{\min}	Minimum required distance to reservoir bottom (100 mm)
$h_{s \min}$	Maximum permissible suction height (800 mm)
$h_{ES \min}$	Minimum height required to prevent axial piston unit from draining (25 mm)

Below-reservoir installation (standard)

Below-reservoir installation means that the axial piston unit is installed outside of the reservoir below the minimum fluid level.

Size 60, 72, 85

▼ **Installation position 1**

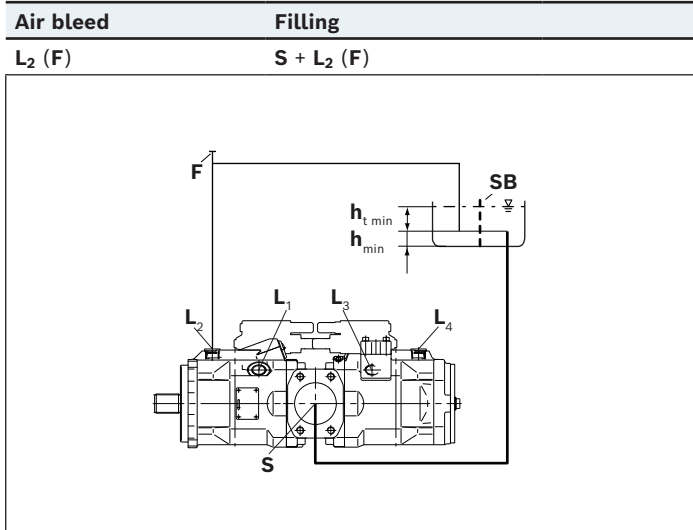

▼ **Installation position 3¹⁾**

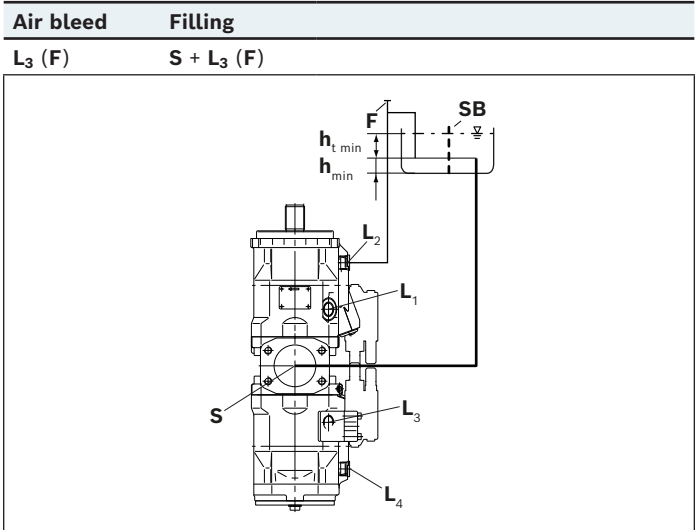

▼ **Installation position 2**

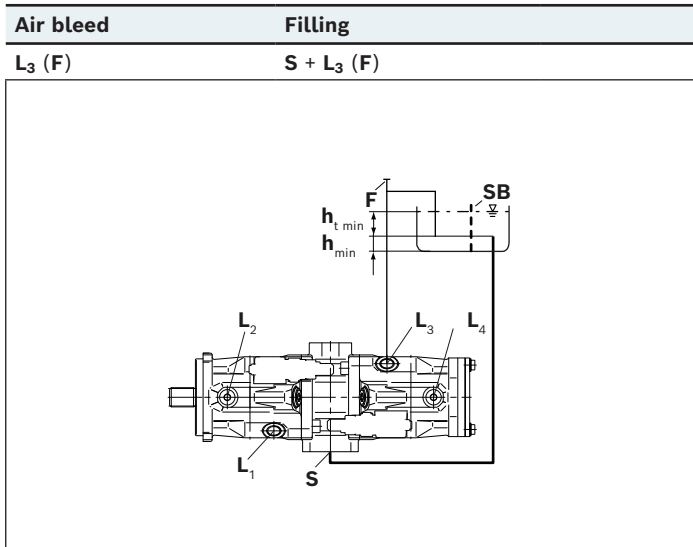

▼ **Installation position 4¹⁾**

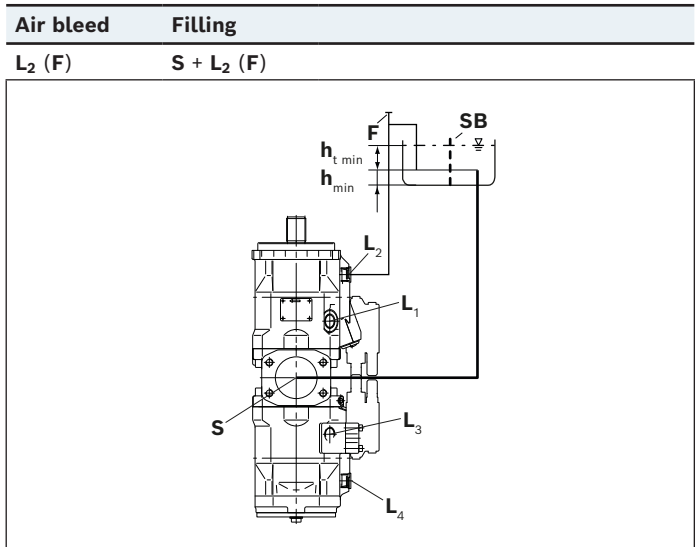

1) Because complete air bleeding and filling are not possible in this position, the pump should be air bled and filled in a horizontal position before installation.

Sizes 95 to 260

▼ **Installation position 5**

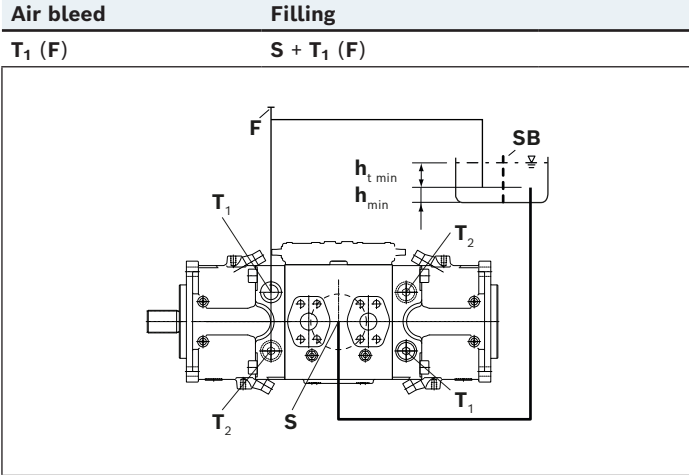

▼ **Installation position 6**

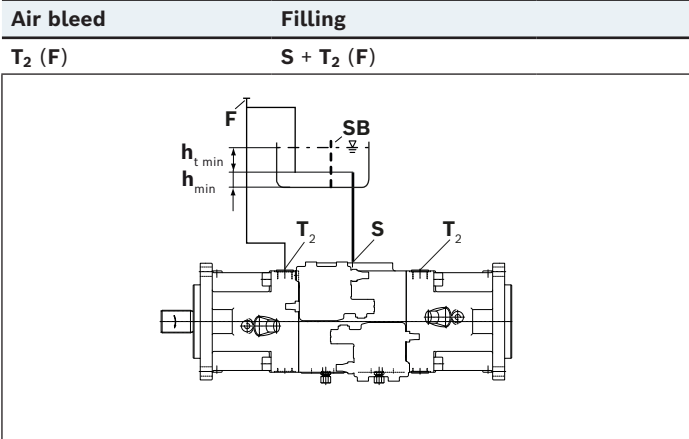

Size 520

▼ **Installation position 7**

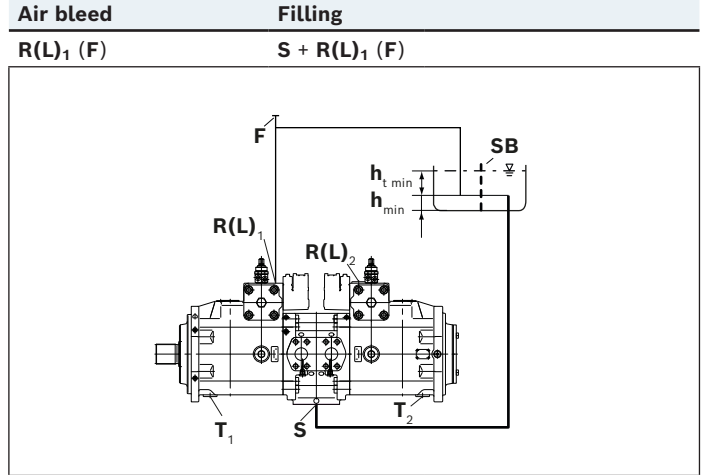

▼ **Installation position 8**

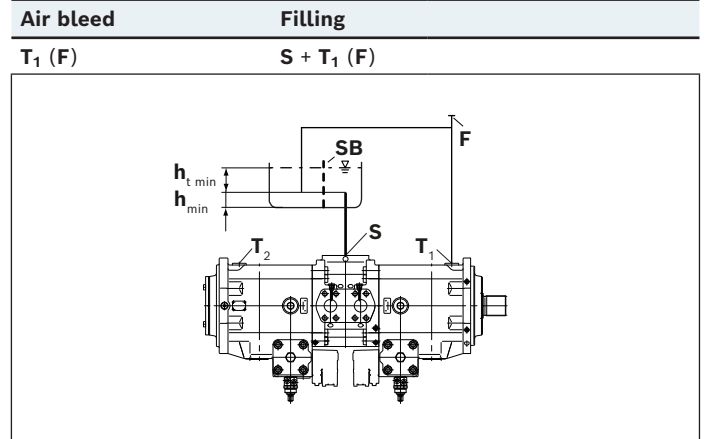

Above-reservoir installation

Above-reservoir installation means that the axial piston unit is installed above the minimum fluid level of the reservoir. Observe the maximum permissible suction height $h_{S \max} = 800 \text{ mm}$.

Above-reservoir installation is not permissible for size 520.

Size 60, 72, 85

▼ Installation position 9

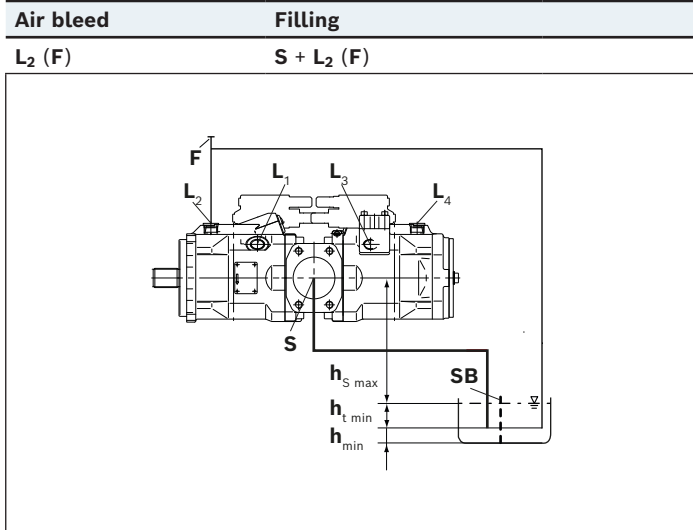

▼ Installation position 11

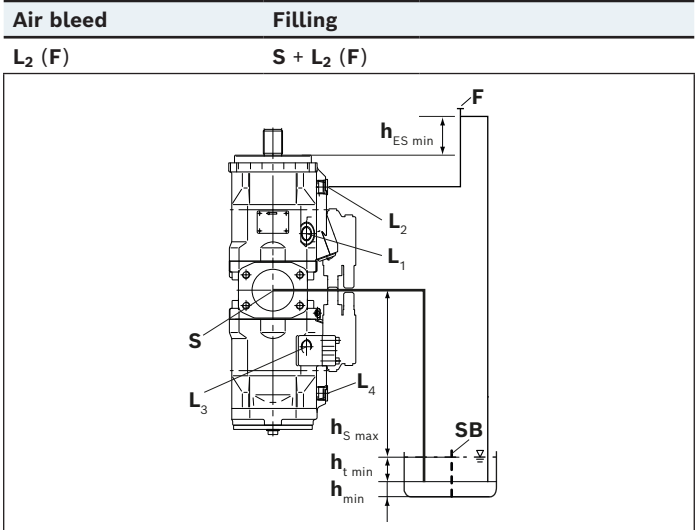

▼ Installation position 10

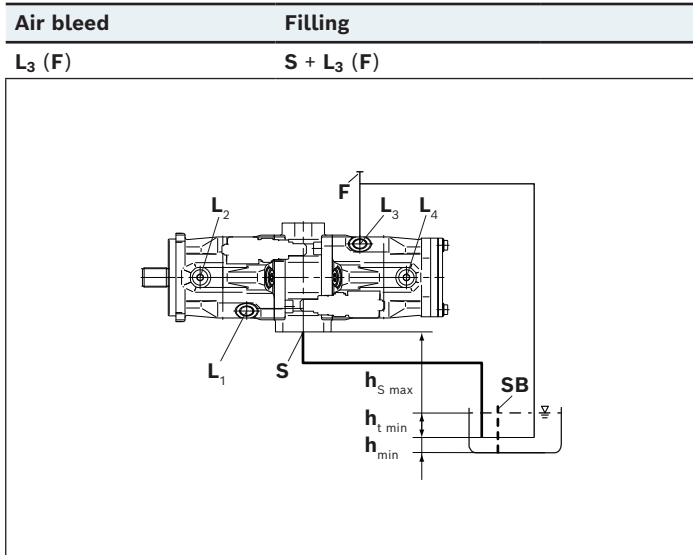

▼ Installation position 12

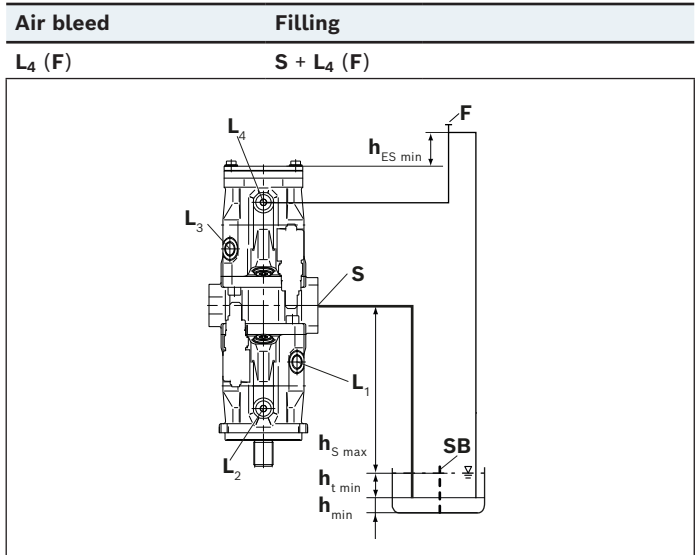

1) Because complete air bleeding and filling are not possible in this position, the pump should be air bled and filled in a horizontal position before installation.

Sizes 95 to 260

▼ **Installation position 13**

Air bleed	Filling
T ₁ (F ₁ , F ₂)	S + T ₁ (F ₁ , F ₂)

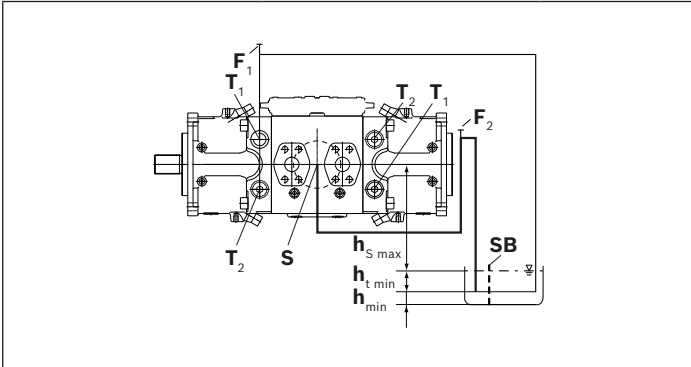

▼ **Installation position 14**

Air bleed	Filling
T ₂ (F ₁ , F ₂)	S + T ₂ (F ₁ , F ₂)

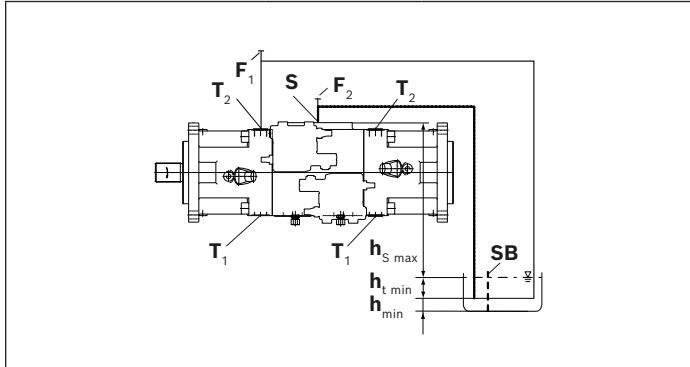

Inside-reservoir installation

Inside-reservoir installation is when the axial piston unit is installed in the reservoir below the minimum fluid level. The axial piston unit is completely below the hydraulic fluid.

If the minimum fluid level is equal to or below the upper edge of the pump, see chapter "**Above-reservoir installation**".

Axial piston units with electrical components (e.g. electric control, sensors) may not be installed in a reservoir below the fluid level.

Notice

Our advice is to fit a suction pipe to the suction port **S** and to fit a pipe to the drain port **L₂, L₃, T₁** or **R(L)₁**. In this case, the other drain port must be plugged. The housing of the axial piston unit must be filled (see installation position 15 to 18) before fitting the piping and filling the reservoir with hydraulic fluid.

Size 60, 72, 85

▼ **Installation position 15**

	Air bleed	Filling
	L₂, L₄	The housing of the axial piston unit is to be filled via L₂, L₄ before attachment of the piping.

▼ **Installation position 16**

	Air bleed	Filling
	L₂, L₃	The housing of the axial piston unit is to be filled via L₂, L₃ before attachment of the piping.

Sizes 95 to 260

▼ **Installation position 17**

	Air bleed	Filling
	T₁, T₂	The housing of the axial piston unit is to be filled via T₁, T₂ before attachment of the piping.

▼ **Installation position 18**

	Air bleed	Filling
	T₁	The housing of the axial piston unit is to be filled via T₁ before attachment of the piping.

Size 520

▼ **Installation position 19**

	Air bleed	Filling
	R(L)₁ R(L)₂	The housing of the axial piston unit is to be filled via R(L)₁ R(L)₂ before attachment of the piping.

Project planning notes

- ▶ The axial piston variable double pump A20VO, A20VNO, A20VLO is intended to be used in an open circuit.
- ▶ The project planning, installation and commissioning of the axial piston unit requires the involvement of skilled personnel.
- ▶ Before using the axial piston unit, please read the corresponding operating instructions completely and thoroughly. If necessary, this can be requested from Bosch Rexroth.
- ▶ Before finalizing your design, please request a binding installation drawing.
- ▶ The specified data and notes contained herein must be observed.
- ▶ Depending on the operating conditions of the axial piston unit (working pressure, fluid temperature), the characteristic curve may shift.
- ▶ The characteristic curve may also shift due to the dither frequency or control electronics.
- ▶ Preservation: Our axial piston units are supplied as standard with preservation protection for a maximum of 12 months. If longer preservation protection is required (maximum 24 months), please specify this in plain text when placing your order. The preservation periods apply under optimal storage conditions, details of which can be found in the data sheet 90312 or the operating instructions.
- ▶ Not all configuration variants of the product are approved for use in a safety function according to ISO 13849. Please consult the proper contact at Bosch Rexroth if you require reliability parameters (e.g., $MTTF_d$) for functional safety.
- ▶ Depending on the type of control used, electromagnetic effects can be produced when using solenoids. Applying a direct voltage signal (DC) to solenoids does not create electromagnetic interference (EMI) nor is the solenoid affected by EMI. Electromagnetic interference (EMI) potential exists when operating and controlling a solenoid with a modulated direct voltage signal (e.g. PWM signal). Appropriate testing and measures should be taken by the machine manufacturer to ensure other components or operators (e.g. with pacemaker) are not affected by this potential.
- ▶ Pressure control (hydraulic or electronic) is not an adequate safeguard against pressure overload. A pressure relief valve should therefore be provided in the hydraulic system. In this connection, observe the technical limits of the pressure relief valve.
- ▶ For controllers requiring external pilot pressure, sufficient control fluid must be provided to the associated ports to ensure the required pilot pressures for the respective controller function. These controllers are subject to leakage due to their design. An increase in control fluid demand has to be anticipated over the total operating time. The design of the control fluid supply must thus be sufficiently large. If the control fluid is too low, the respective controller function may be impaired and undesired system behavior may result.
- ▶ Please note that a hydraulic system is an oscillating system. This can lead, for example, to the stimulation the natural frequency within the hydraulic system during operation at constant rotational speed over a long period of time. The excitation frequency of the pump is 9 times the rotational speed frequency. This can be prevented, for example, with suitably designed hydraulic lines.
- ▶ Please note the information regarding the tightening torques of port threads and other screw connections in the operating instructions.
- ▶ The ports and fastening threads are designed for the p_{max} permissible pressures of the respective ports, see the connection tables. The machine or system manufacturer must ensure that the connecting elements and lines correspond to the specified application conditions (pressure, flow, hydraulic fluid, temperature) with the necessary safety factors.
- ▶ The service ports and function ports are only intended to accommodate hydraulic lines.

Safety instructions

- ▶ During and shortly after operation, there is a risk of getting burnt on the axial piston unit and especially on the solenoids. Take the appropriate safety measures (e.g. by wearing protective clothing).
- ▶ Moving parts in control equipment (e.g. valve spools) can, under certain circumstances, get stuck in position as a result of contamination (e.g. contaminated hydraulic fluid, abrasion, or residual dirt from components). As a result, the hydraulic fluid flow and the build-up of torque in the axial piston unit can no longer respond correctly to the operator's specifications. Even the use of various filter elements (external or internal flow filtration) will not rule out a fault but merely reduce the risk. The machine/system manufacturer must test whether remedial measures are needed on the machine for the application concerned in order to bring the driven consumer into a safe position (e.g. safe stop) and ensure any measures are properly implemented.

Related documentation

Document type	Title	Document number
Data sheet	Axial piston variable Pump A10VO Size 60, 72, series 5x	92703
	Axial piston variable pump A10VNO Size 85, series 5x	92735
	Axial piston variable pump A4VSO Size 520, series 1X and 30	92050
	Control systems DR, DP, FR and DFR for axial piston variable pump A4VSO, size 520	92060
	Power controller LR2, LR3 and LR2N, LR3N for A4VSO, size 520	92064
	Control systems HM, HS, HS5 and EO for axial piston variable pump A4VSO size 520	92076
	Axial piston variable pump A11V(L)O Size 95, 190, and 260, series 1X	92500
Operating instructions	Axial piston variable double pump A20V(L)O	93100-01-B

Bosch Rexroth AG

An den Kelterwiesen 14
72160 Horb a.N.
Germany
Phone +49 7451 92-0
sales.industry.horb@boschrexroth.de
sales.mobile.horb@boschrexroth.de
www.boschrexroth.com

Bosch Rexroth AG

Glockeraustrasse 2
89275 Elchingen
Germany
Phone +49 7308 82-0
info.ma@boschrexroth.de
www.boschrexroth.com

© Bosch Rexroth AG 2006. All rights reserved, also regarding any disposal, exploitation, reproduction, editing, distribution, as well as in the event of applications for industrial property rights. The data specified within only serve to describe the product. As our products are constantly being further developed, no statements concerning a certain condition or suitability for a certain application can be derived from our information. The information given does not release the user from the obligation of own judgment and verification. It must be remembered that our products are subject to a natural process of wear and aging.